

FEATURES

- Trench Gate IGBT
- Cu Base with Enhanced Al₂O₃ Substrates
- 10µs Short Circuit Withstand
- Compact Module

APPLICATIONS

- Motor Drives
- Power Charging Equipment
- Renewable Energy Power Conversion
- High Reliability Inverters
- Electric Vehicles

The Powerline range of high power modules includes half bridge, chopper, dual, single and bi-directional switch configurations covering voltages from 1200V to 6500V and currents up to 2400A.

The DIM450M1HS12-PB500 is a half bridge 1200V, trench gate, insulated gate bipolar transistor (IGBT) module with enhanced field stop and implantation technology. The IGBT has a wide reverse bias safe operating area (RBSOA) plus 10µs short circuit withstand.

trench gate, insulated gate bipolar transistor (IGBT) module with enhanced field stop and implantation technology.

The module incorporates an electrically isolated base plate and low inductance construction enabling circuit designers to optimise circuit layouts and utilise grounded heat sinks for safety.

ORDERING INFORMATION

Order As:

DIM450M1HS12-PB500

Note: When ordering, please use the complete part number

KEY PARAMETERS

V_{CES}	1200V
$V_{CE(sat)}$ * (typ)	1.65V
I_C (max)	450A
$I_{C(PK)}$ (max)	900A

* Measured at the auxiliary terminals

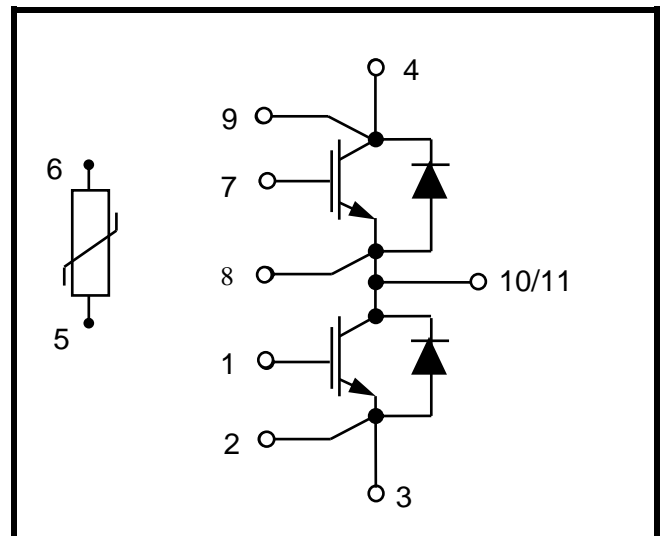

Fig. 1 Circuit configuration



Outline type code: M1

(See Fig. 16 for further information)

Fig. 2 Package

ABSOLUTE MAXIMUM RATINGS

Stresses above those listed under ‘Absolute Maximum Ratings’ may cause permanent damage to the device. In extreme conditions, as with all semiconductors, this may include potentially hazardous rupture of the package. Appropriate safety precautions should always be followed. Exposure to Absolute Maximum Ratings may affect device reliability.

T_{case} = 25°C unless stated otherwise

Symbol	Parameter	Test Conditions	Max.	Units
V _{CES}	Collector-emitter voltage	V _{GE} = 0V, T _C = 25°C	1200	V
V _{GES}	Gate-emitter voltage	T _C = 25°C	±20	V
I _C	Continuous collector current	T _C = 100°C, T _{vjmax} = 175°C	450	A
I _{C(PK)}	Peak collector current	t _p = 1ms	900	A
P _{max}	Max. transistor power dissipation	T _C = 25°C, T _{vj} = 175°C	2.8	kW
I ² t	Diode I ² t value	V _R = 0V, t _p = 10ms, T _{vj} = 150°C	27.2	kA ² s
V _{isol}	Isolation voltage – per module	Commoned terminals to base plate. AC RMS, 1 min, 50Hz	3400	V

THERMAL AND MECHANICAL RATINGS

Internal insulation material:	Al ₂ O ₃
Baseplate material:	Cu
Creepage distance – Terminal to heatsink:	15.0mm
Creepage distance – Terminal to terminal:	13.0mm
Clearance – Terminal to heatsink:	12.5mm
Clearance – Terminal to terminal:	10mm
CTI (Comparative Tracking Index):	>200

Symbol	Parameter	Test Conditions	Min	Typ.	Max	Units
R _{th(j-c)}	Thermal resistance – IGBT	Continuous dissipation - junction to case	-	-	52	°C/kW
R _{th(j-c)}	Thermal resistance – diode		-	-	86	°C/kW
R _{th(c-h)}	Thermal resistance – case to heatsink (IGBT)	Mounting torque 5Nm (with mounting grease 1W/m °C)	-	30	-	°C/kW
R _{th(c-h)}	Thermal resistance – case to heatsink (Diode)		-	45	-	°C/kW
T _j	Junction temperature – under switching conditions	IGBT	-40	-	150	°C
		Diode	-40	-	150	°C
T _{stg}	Storage temperature range	-	-40	-	125	°C
	Screw torque	Mounting – M5	3	-	6	Nm
		Electrical connections – M6	3	-	6	Nm

ELECTRICAL CHARACTERISTICS

$T_{case} = 25^{\circ}C$ unless stated otherwise.

Symbol	Parameter	Test Conditions	Min	Typ	Max	Units
I _{CES}	Collector cut-off current	V _{GE} = 0V, V _{CE} = V _{CES}			1	mA
		V _{GE} = 0V, V _{CE} = V _{CES} , T _C = 125°C			10	mA
		V _{GE} = 0V, V _{CE} = V _{CES} , T _C = 150°C			20	mA
I _{GES}	Gate leakage current	V _{GE} = ± 20V, V _{CE} = 0V			0.5	μA
V _{GE(TH)}	Gate threshold voltage	I _C = 15mA, V _{GE} = V _{CE}	5.3	5.9	6.5	V
V _{CE(sat)}	Collector-emitter saturation voltage	V _{GE} = 15V, I _C = 450A		1.65	2.05	V
		V _{GE} = 15V, I _C = 450A, T _j = 125°C		1.95		V
		V _{GE} = 15V, I _C = 450A, T _j = 150°C		2.0		V
I _F	Diode forward current	DC		450		A
I _{FM}	Diode maximum forward current	t _p = 1ms		900		A
V _F	Diode forward voltage	I _F = 450A		1.65	2.05	V
		I _F = 450A, T _j = 125°C		1.75		V
		I _F = 450A, T _j = 150°C		1.75		V
C _{ies}	Input capacitance	V _{CE} = 25V, V _{GE} = 0V, f = 100kHz		62		nF
Q _g	Gate charge	±15V		4.6		μC
C _{res}	Reverse transfer capacitance	V _{CE} = 25V, V _{GE} = 0V, f = 1MHz		0.82		nF
L _M	Module inductance			20		nH
R _{INT}	Internal transistor resistance			1.2		Ω
R _{CC+EE'}	Module lead resistance, terminal to chip			1.1		mΩ
SC _{Data}	Short circuit current, I _{SC}	T _j = 150°C, V _{CC} = 800V t _p ≤ 10μs, V _{GE} ≤ 15V V _{CE(max)} = V _{CES} - L* x di/dt IEC 60747-9		1900		A

Note:

* L is the circuit inductance + L_M

NTC-Thermistor Data

Symbol	Parameter	Test Conditions	Min	Typ	Max	Units
R ₂₅	Rated resistance	T _C = 25°C		5		kΩ
ΔR/R	Deviation of R ₁₀₀	T _C = 100°C, R ₁₀₀ = 493Ω	-5		5	%
P ₂₅	Power dissipation	T _C = 25°C			20	mW
B _{25/50}	B-value	R ₂ = R ₂₅ exp [B _{25/50} (1/T ₂ - 1/(298.15K))]		3375		K
B _{25/80}		R ₂ = R ₂₅ exp [B _{25/80} (1/T ₂ - 1/(298.15K))]		3411		K
B _{25/100}		R ₂ = R ₂₅ exp [B _{25/100} (1/T ₂ - 1/(298.15K))]		3433		K

Caution: This device is sensitive to electrostatic discharge. Users should follow ESD handling procedures

ELECTRICAL CHARACTERISTICS

T_{case} = 25°C unless stated otherwise

Symbol	Parameter	Test Conditions		Min	Typ.	Max	Units
t _{d(off)}	Turn-off delay time	I _C = 450A V _{CE} = 600V V _{GE} = ±15V L _S ~ 35nH	R _{G(OFF)} = 2.2Ω		510		ns
t _f	Fall time				170		ns
E _{OFF}	Turn-off energy loss				37		mJ
t _{d(on)}	Turn-on delay time		R _{G(ON)} = 0.5Ω		190		ns
t _r	Rise time				50		ns
E _{ON}	Turn-on energy loss				19.0		mJ
Q _{rr}	Diode reverse recovery charge	I _F = 450A V _{CE} = 600V			45		μC
I _{rr}	Diode reverse recovery current				410		A
E _{rec}	Diode reverse recovery energy				21		mJ

T_{case} = 125°C unless stated otherwise

Symbol	Parameter	Test Conditions		Min	Typ.	Max	Units
t _{d(off)}	Turn-off delay time	I _C = 450A V _{CE} = 600V V _{GE} = ±15V L _S ~ 35nH	R _{G(OFF)} = 2.2Ω		570		ns
t _f	Fall time				200		ns
E _{OFF}	Turn-off energy loss				50		mJ
t _{d(on)}	Turn-on delay time		R _{G(ON)} = 0.5Ω		200		ns
t _r	Rise time				60		ns
E _{ON}	Turn-on energy loss				31.5		mJ
Q _{rr}	Diode reverse recovery charge	I _F = 450A V _{CE} = 600V			71		μC
I _{rr}	Diode reverse recovery current				455		A
E _{rec}	Diode reverse recovery energy				36		mJ

T_{case} = 150°C unless stated otherwise

Symbol	Parameter	Test Conditions		Min	Typ.	Max	Units
t _{d(off)}	Turn-off delay time	I _C = 450A V _{CE} = 600V V _{GE} = ±15V L _S ~ 35nH	R _{G(OFF)} = 2.2Ω dv/dt = 5200V/μs		580		ns
t _f	Fall time				200		ns
E _{OFF}	Turn-off energy loss				52.5		mJ
t _{d(on)}	Turn-on delay time		R _{G(ON)} = 0.5Ω di/dt = 7000A/μs		200		ns
t _r	Rise time				60		ns
E _{ON}	Turn-on energy loss				39.0		mJ
Q _{rr}	Diode reverse recovery charge	I _F = 450A V _{CE} = 600V di/dt = 7000A/μs			87		μC
I _{rr}	Diode reverse recovery current				460		A
E _{rec}	Diode reverse recovery energy				40		mJ

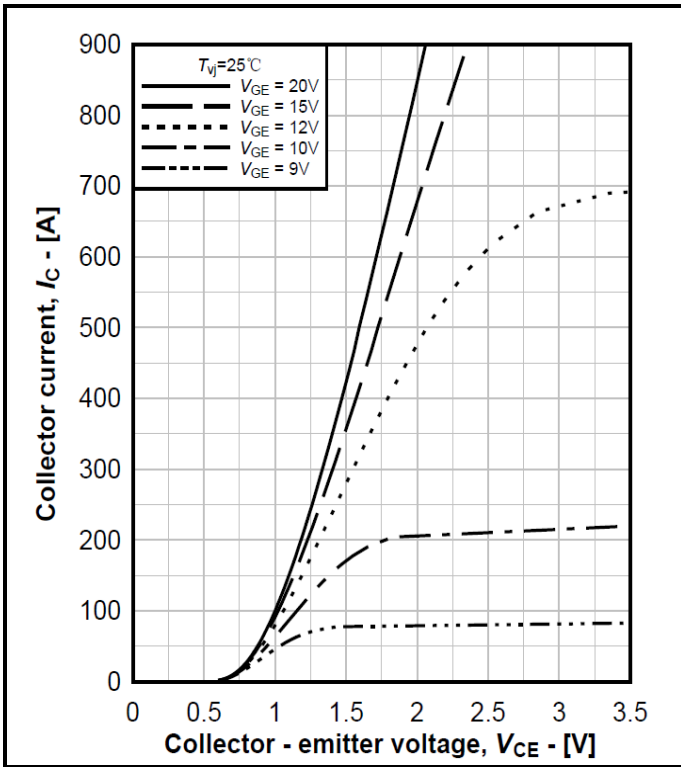

Fig. 3 Typical IGBT output characteristics, $I_C = f(V_{CE})$

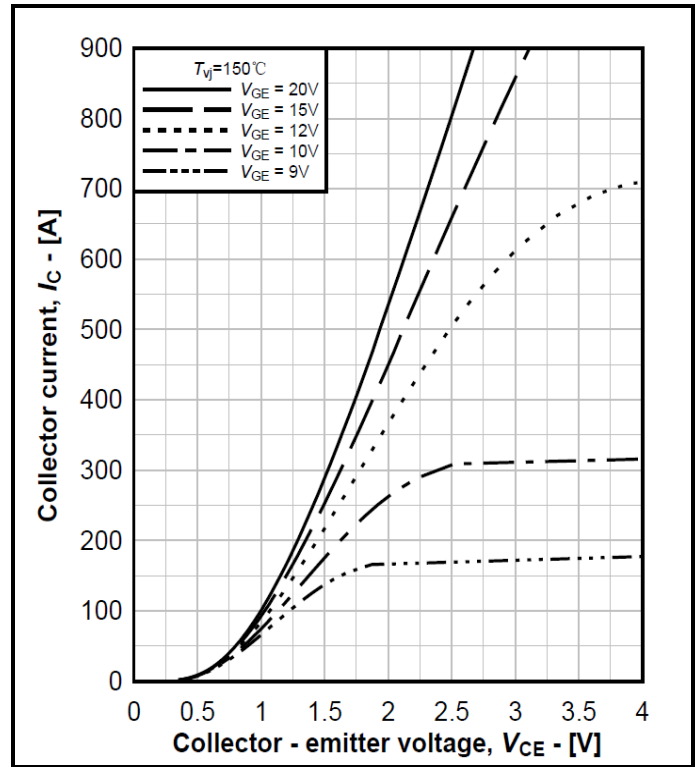

Fig. 4 Typical IGBT output characteristics, $I_C = f(V_{CE})$

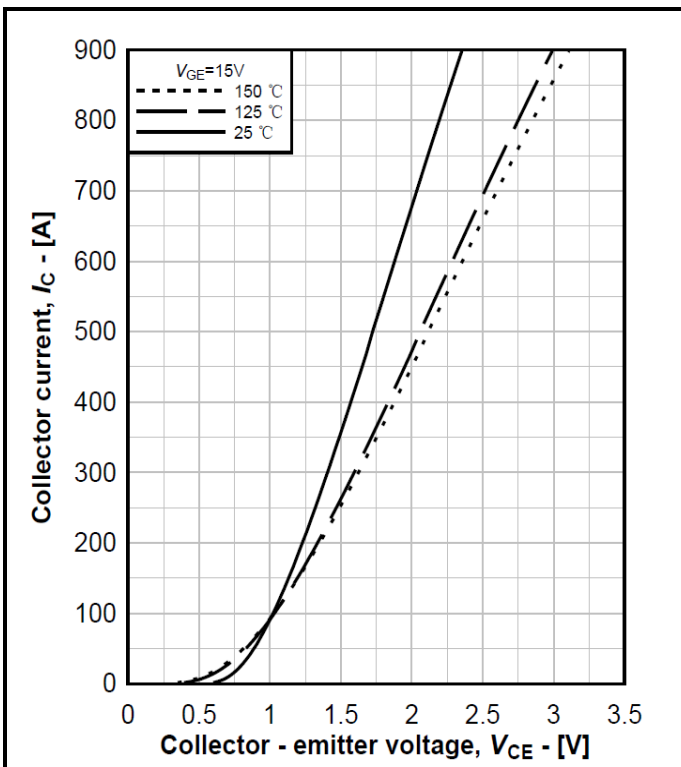

Fig. 5 Typical IGBT output characteristics, $I_C = f(V_{CE})$

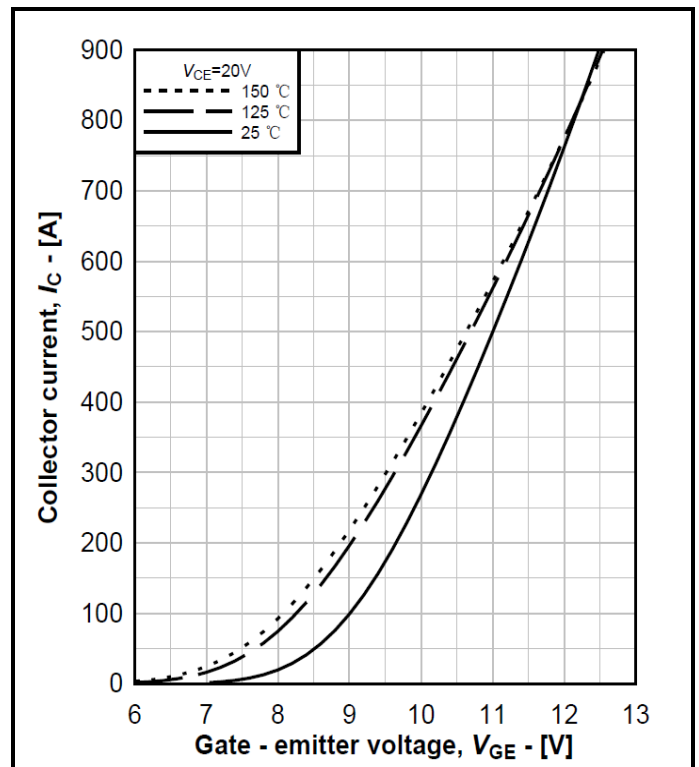

Fig. 6 Typical IGBT transfer characteristics, $I_C = f(V_{GE})$

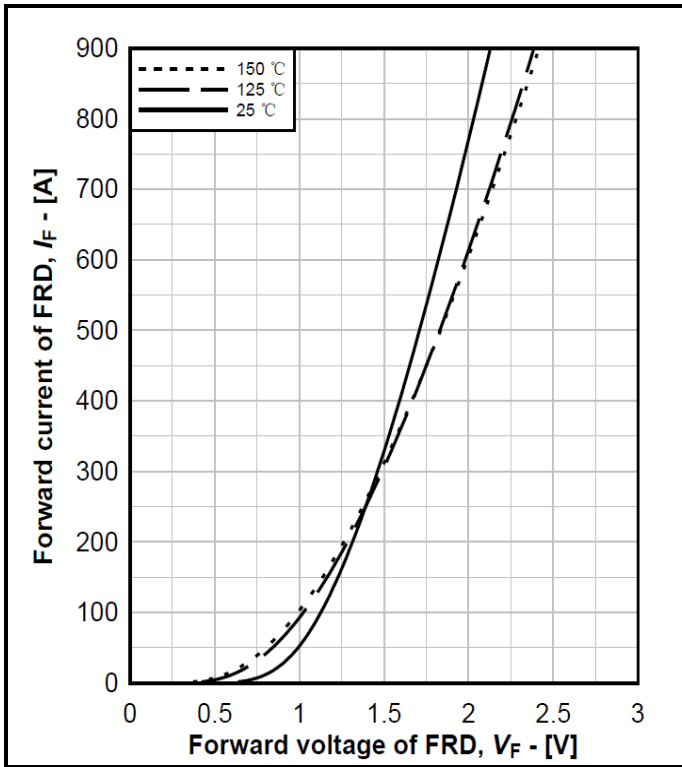

Fig. 7 Diode typical forward characteristics, $I_F = f(V_F)$

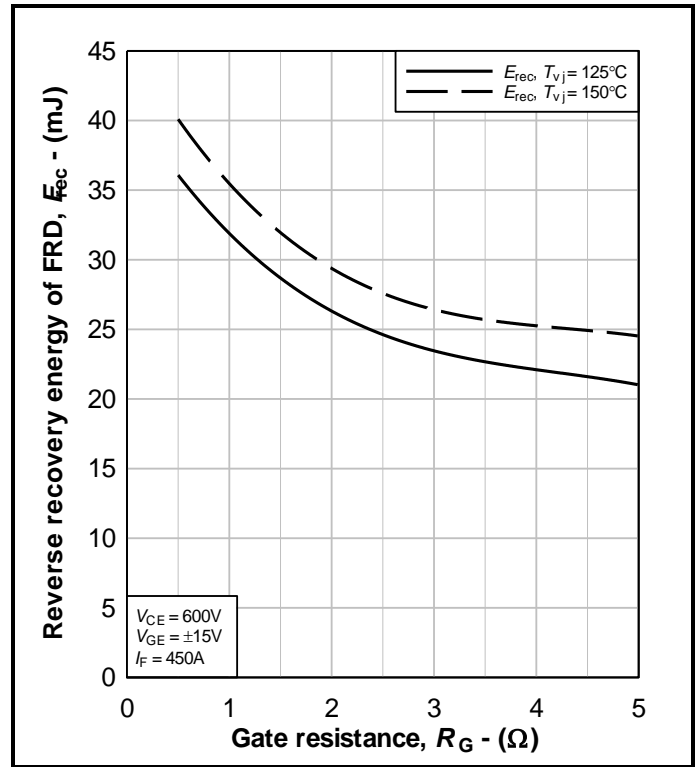

Fig. 8 Typical FRD E_{rec} , $E_{rec} = f(R_G)$

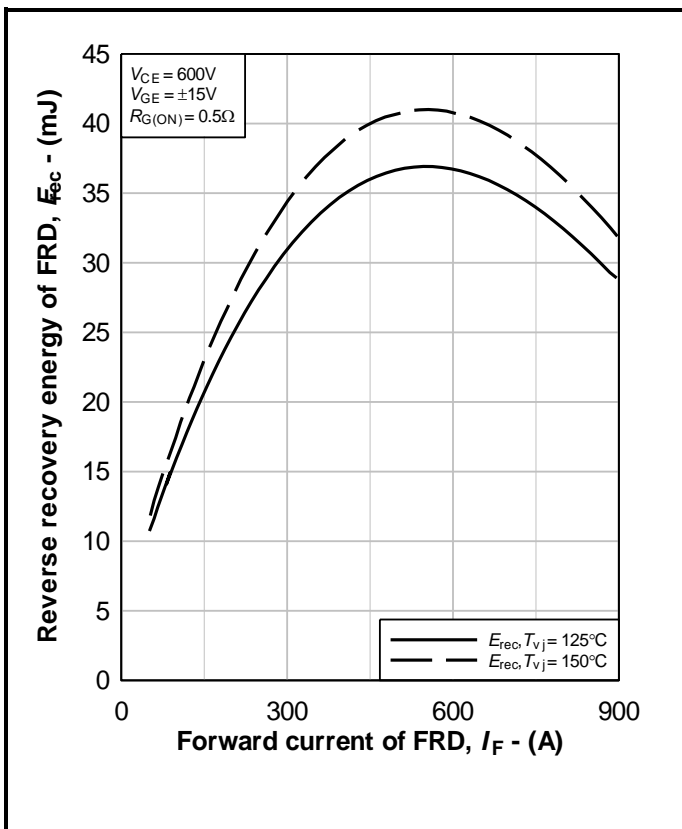

Fig. 9 Typical FRD E_{rec} , $E_{rec} = f(I_F)$

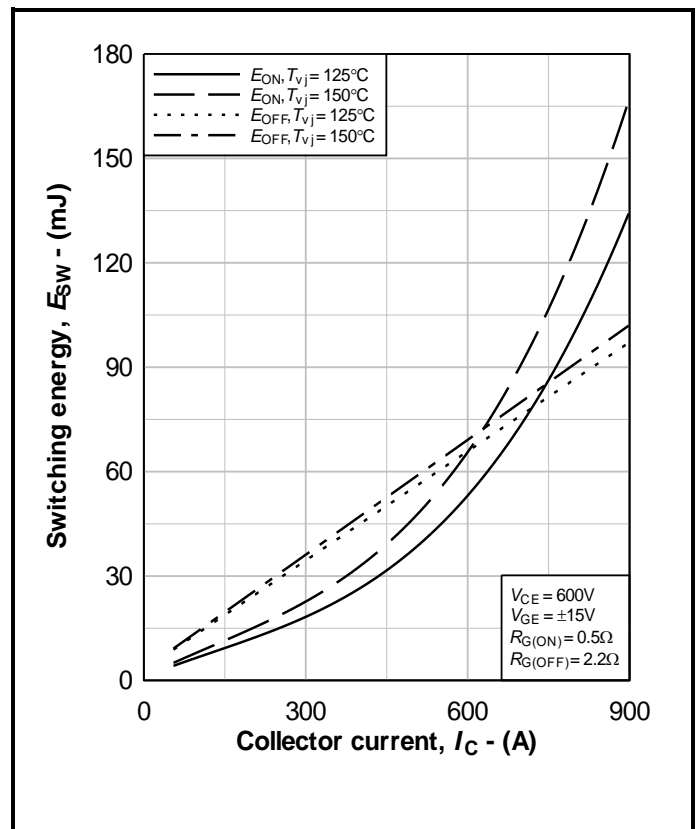

Fig. 10 Typical IGBT switching energy, $E_{ON} = f(I_C)$, $E_{OFF} = f(I_C)$

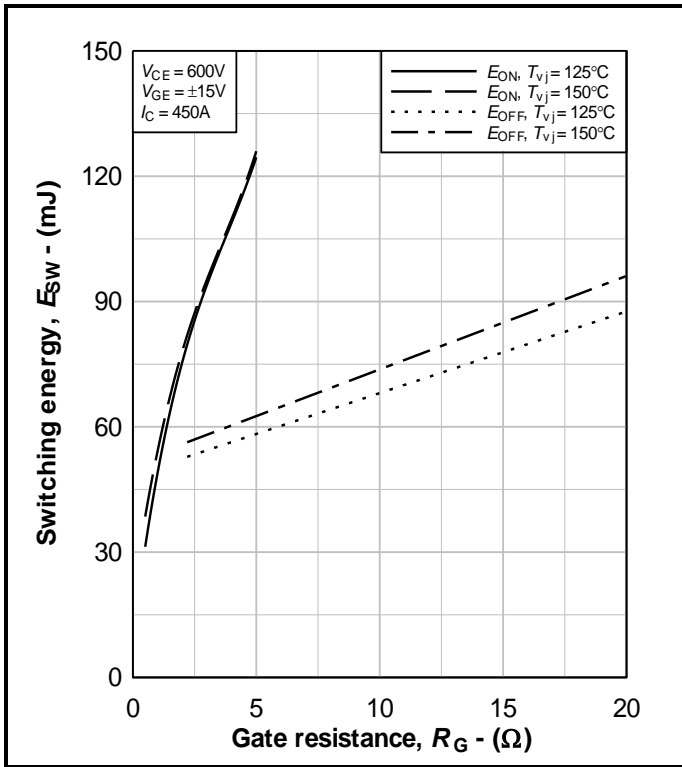

Fig. 11 Typical IGBT switching energy
 $E_{ON} = f(R_G)$, $E_{OFF} = f(R_G)$

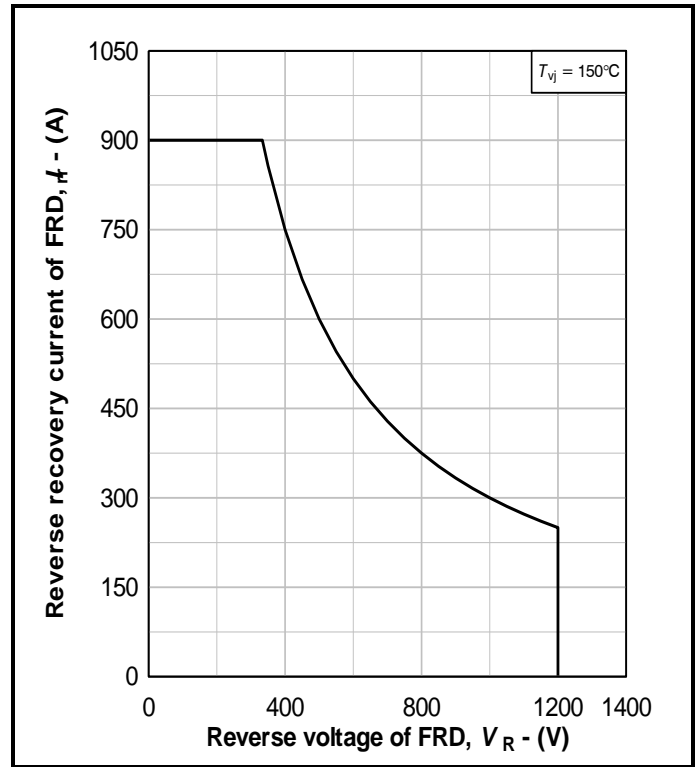

Fig. 12 Diode reverse bias safe operating area

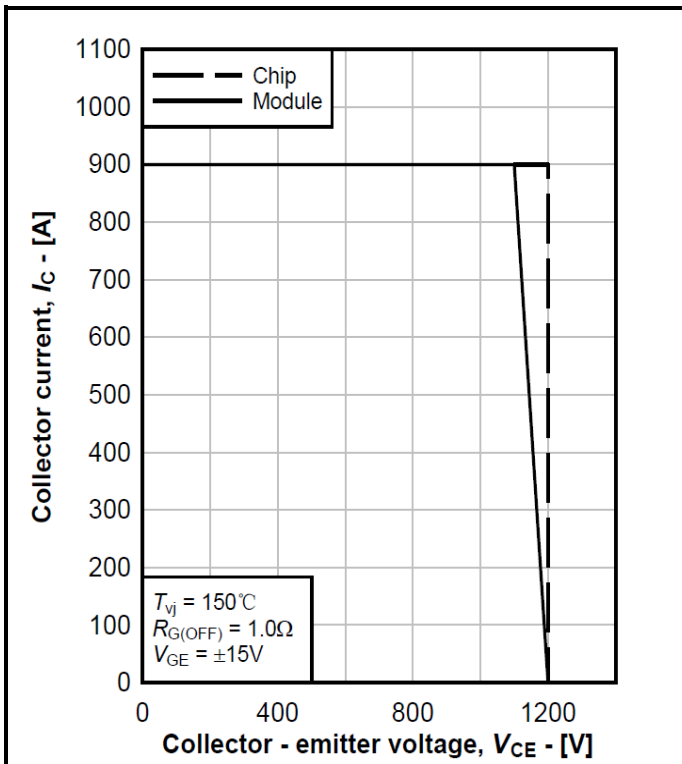

Fig. 13 Reverse bias safe operating area of IGBT,
 $I_C = f(V_{CE})$

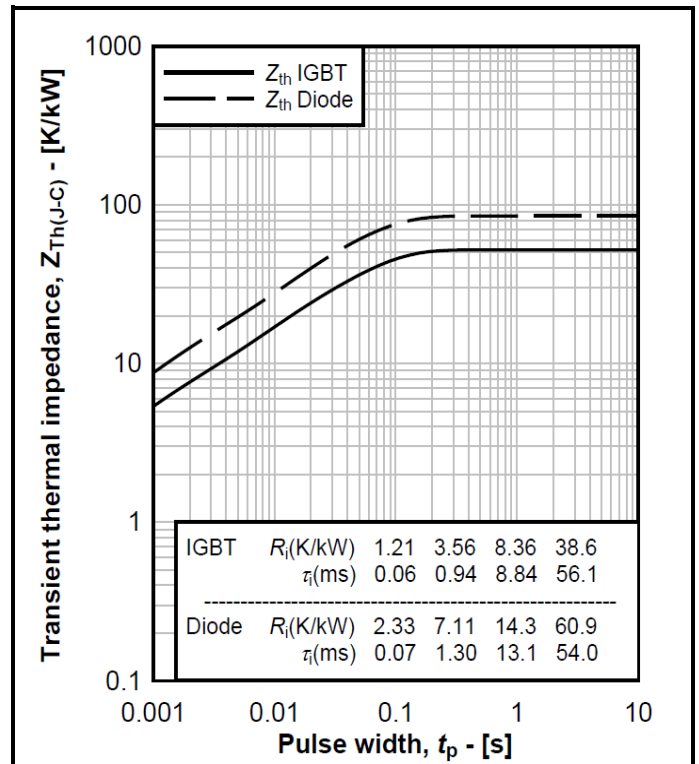

Fig. 14 Transient thermal impedance, $Z_{th(J-C)} = f(t)$

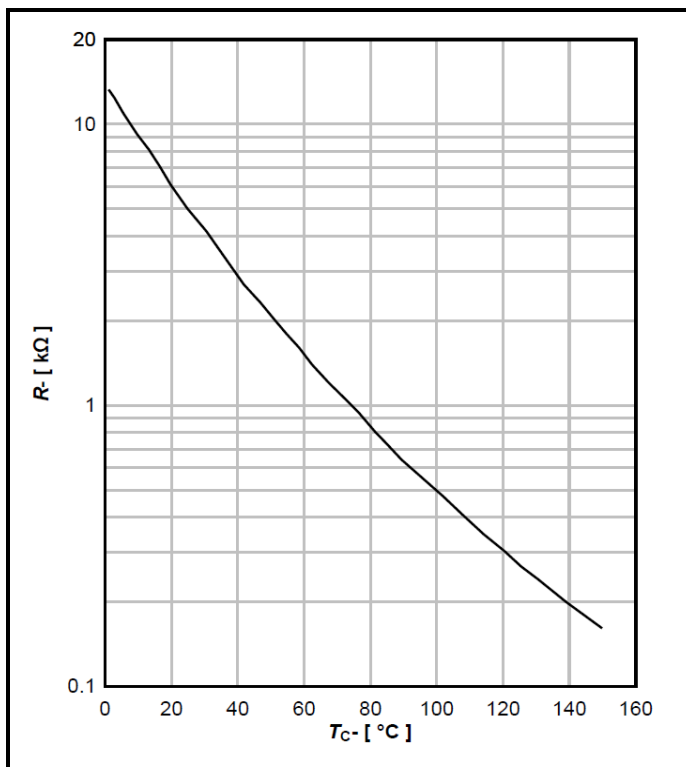

Fig. 15 Typical NTC thermistor characteristic, $R = f(T_c)$

IMPORTANT INFORMATION:

This publication is provided for information only and not for resale.

The products and information in this publication are intended for use by appropriately trained technical personnel.

Due to the diversity of product applications, the information contained herein is provided as a general guide only and does not constitute any guarantee of suitability for use in a specific application. The user must evaluate the suitability of the product and the completeness of the product data for the application. The user is responsible for product selection and ensuring all safety and any warning requirements are met. Should additional product information be needed please contact Customer Service.

Although we have endeavoured to carefully compile the information in this publication it may contain inaccuracies or typographical errors. The information is provided without any warranty or guarantee of any kind.

This publication is an uncontrolled document and is subject to change without notice. When referring to it please ensure that it is the most up to date version and has not been superseded.

The products are not intended for use in applications where a failure or malfunction may cause loss of life, injury or damage to property. The user must ensure that appropriate safety precautions are taken to prevent or mitigate the consequences of a product failure or malfunction.

The products must not be touched when operating because there is a danger of electrocution or severe burning. Always use protective safety equipment such as appropriate shields for the product and wear safety glasses. Even when disconnected any electric charge remaining in the product must be discharged and allowed to cool before safe handling using protective gloves.

Extended exposure to conditions outside the product ratings may affect reliability leading to premature product failure. Use outside the product ratings is likely to cause permanent damage to the product. In extreme conditions, as with all semiconductors, this may include potentially hazardous rupture, a large current to flow or high voltage arcing, resulting in fire or explosion. Appropriate application design and safety precautions should always be followed to protect persons and property.

Product Status & Product Ordering:

We annotate datasheets in the top right hand corner of the front page, to indicate product status if it is not yet fully approved for production. The annotations are as follows:-

Target Information:	This is the most tentative form of information and represents a very preliminary specification. No actual design work on the product has been started.
Preliminary Information:	The product design is complete and final characterisation for volume production is in progress. The datasheet represents the product as it is now understood but details may change.
No Annotation:	The product has been approved for production and unless otherwise notified by Dynex any product ordered will be supplied to the current version of the data sheet prevailing at the time of our order acknowledgement.

All products and materials are sold and services provided subject to Dynex's conditions of sale, which are available on request.

Any brand names and product names used in this publication are trademarks, registered trademarks or trade names of their respective owners.

HEADQUARTERS OPERATIONS

DYNEX SEMICONDUCTOR LTD

Doddington Road, Lincoln, Lincolnshire, LN6 3LF,
United Kingdom

Tel: +44(0)1522 500500

Web: <http://www.dynexsemi.com>

CUSTOMER SERVICE

DYNEX SEMICONDUCTOR LTD

Doddington Road, Lincoln, Lincolnshire, LN6 3LF,
United Kingdom

Tel: +44(0)1522 502753 / 502901

Email: powersolutions@dynexsemi.com

© Dynex Semiconductor Ltd. 2018. Technical Documentation – Not for resale.