

178 Centres Bar Clamp

DS6376-1 September 2021 LN41175

DESCRIPTION

Dynex offers a range of standard clamps designed to accommodate press pack semiconductors, with tie rod centres from 75mm to 210mm and clamping force from 5kN to 138kN.

The set clamps use Disc Springs to DIN 2092/2093 to apply the clamping force over a wide temperature range. The clamps also incorporate pressure indicators to make installation simple. A high quality moulded insulator and PTFE sleeving provide isolation from the top and bottom sides of the device.

Zinc plating with a Yellow Passivated finish is used for enhanced corrosion protection.

If a clamp you require is not available in our standard range, Dynex can provide a clamping solution to your individual needs. Speak to your local sales representative for details.

ORDERING INFORMATION

Example Part Number:

DC178-2/83/200

DC178-2 – Clamp Series

This is a Dynex clamp with tie rod centres of 178mm

83 – Clamping Force

This is the required clamping force of the semiconductor device in kN

200 – Dimension 'Y' (see figure 2)

This is the total distance of all the parts to be clamped.

Tie Rod Centres (mm) **178**
Forces available (kN) **73, 83**

The DC178-2 has been designed to support the common semiconductor packages shown below.

Dynex Outline	Flange Diameter (mm)	Height (mm)
A	148	35
B	120	35.6
M	148	26.5
W	120	26.5

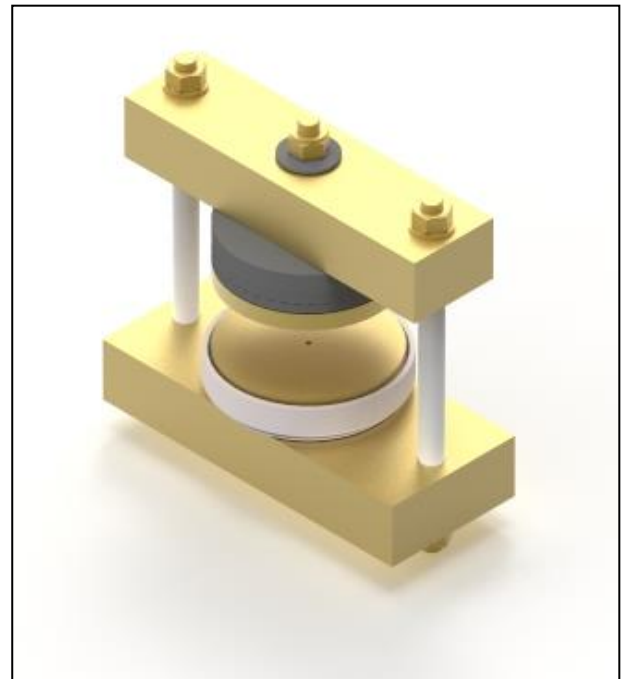
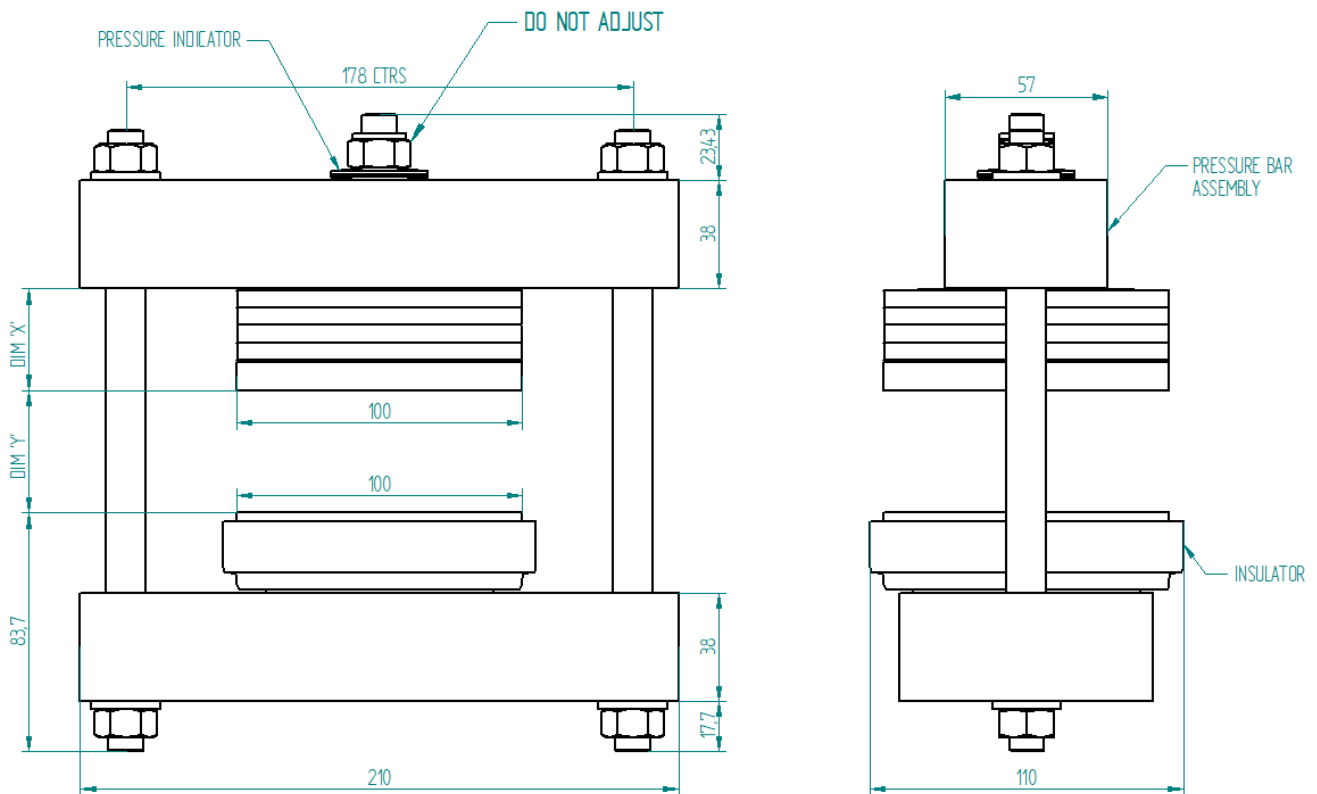

Figure 1: Clamp General Assembly

178 Centres Bar Clamp

All dimensions in mm, unless stated otherwise.
DO NOT SCALE.



FORCE	DIM 'X'
73kN	54.13
83kN	53.77

Figure 2: Clamp Outline

178 Centres Bar Clamp

IMPORTANT INFORMATION:

This publication is provided for information only and not for resale.

The products and information in this publication are intended for use by appropriately trained technical personnel.

Due to the diversity of product applications, the information contained herein is provided as a general guide only and does not constitute any guarantee of suitability for use in a specific application. The user must evaluate the suitability of the product and the completeness of the product data for the application. The user is responsible for product selection and ensuring all safety and any warning requirements are met. Should additional product information be needed please contact Customer Service.

Although we have endeavoured to carefully compile the information in this publication it may contain inaccuracies or typographical errors. The information is provided without any warranty or guarantee of any kind.

This publication is an uncontrolled document and is subject to change without notice. When referring to it please ensure that it is the most up to date version and has not been superseded.

The products are not intended for use in applications where a failure or malfunction may cause loss of life, injury or damage to property. The user must ensure that appropriate safety precautions are taken to prevent or mitigate the consequences of a product failure or malfunction.

The products must not be touched when operating because there is a danger of electrocution or severe burning. Always use protective safety equipment such as appropriate shields for the product and wear safety glasses. Even when disconnected any electric charge remaining in the product must be discharged and allowed to cool before safe handling using protective gloves.

Extended exposure to conditions outside the product ratings may affect reliability leading to premature product failure. Use outside the product ratings is likely to cause permanent damage to the product. In extreme conditions, as with all semiconductors, this may include potentially hazardous rupture, a large current to flow or high voltage arcing, resulting in fire or explosion. Appropriate application design and safety precautions should always be followed to protect persons and property.

Product Status & Product Ordering:

We annotate datasheets in the top right hand corner of the front page, to indicate product status if it is not yet fully approved for production. The annotations are as follows:

Target Information:	This is the most tentative form of information and represents a very preliminary specification. No actual design work on the product has been started.
Provisional Information:	Some initial development work has been performed. The datasheet represents a view of the end product based on very limited information. Certain details will change.
Preliminary Information:	The product design is complete and final characterisation for volume production is in progress. The datasheet represents the product as it is now understood but details may change.
No Annotation:	The product has been approved for production and unless otherwise notified by Dynex any product ordered will be supplied to the current version of the data sheet prevailing at the time of our order acknowledgement.

All products and materials are sold and services provided subject to Dynex's conditions of sale, which are available on request.

Any brand names and product names used in this publication are trademarks, registered trademarks or trade names of their respective owners.

HEADQUARTERS OPERATIONS

DYNEX SEMICONDUCTOR LIMITED
Doddington Road, Lincoln, Lincolnshire. LN6 3LF
United Kingdom.
Phone: +44 (0) 1522 500500
Fax: +44 (0) 1522 500550
Web: <http://www.dynexsemi.com>

CUSTOMER SERVICE

Phone: +44 (0) 1522 502753 / 502901
e-mail: powersolutions@dynexsemi.com