

AN6148

Thyristor Gate Drives

Application Note

AN6148-1 June 2014 (LN31657)

Introduction

The output of the electronics that control the sequence of firing of thyristors is at logic level of a few volts, negligible current and usually at ground potential. The thyristors require a firing signal that is tens of volts and tens to hundreds of milliamps. In addition, the thyristor is often at a high potential above ground. The circuit that links these disparate conditions is the gate drive circuit. The purpose of the gate drive circuit is to provide a current pulse of the required shape, peak value, duration and frequency when prompted by the output from the control electronics. Also, the outputs from the gate drives invariably have to be isolated from one another because the thyristors in a converter normally have potentials that differ by many hundreds of volts. This isolation is realised with the use of pulse transformers as shown in figure 1.

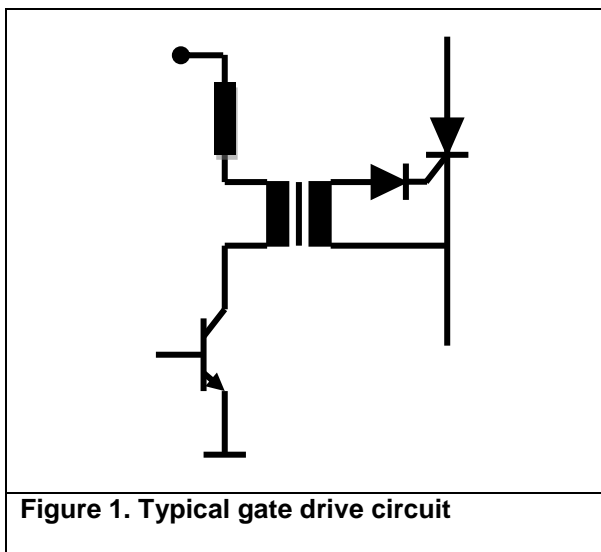

Usually triggering is inhibited when the anode voltage of the thyristor is negative. This is because, in this mode, the thyristor acts like a low gain transistor and amplifies the gate current which is seen as an increase in anode leakage current. This together with the blocking voltage across the device gives a significant increase in power dissipation in the thyristor. This extra power loss has to be considered when dimensioning the heat-sinks otherwise the device can overheat. But perhaps its most significant effect is associated with series connected thyristors where the increase in leakage current can make achieving voltage sharing between the thyristors much more difficult.

Although with many power circuits a pulse of 100µs to 150µs is sufficient to turn the thyristor on and maintain it in conduction, some circuits require the gate current to continue throughout the conducting period, while in other cases a train of short pulses during the conduction period is sufficient. The voltage may temporarily reverse during the conduction period or there may not be positive volts present at the initial point of firing. In the extreme, in the case of a AC converter with an inductive load for instance, a pulse duration of 180°- ϕ is required i.e. up to 10ms for 50Hz. The most suitable system depends upon the power circuit being employed. However, the gate pulse should only be made as long as is necessary because the magnitude of the average gate power has to be considered and the longer the gate pulse the higher the average power and hence additional heating and possible destruction of the thyristor.

In practice it is uneconomic to produce gate drives with very long pulses for reasons of power requirements and availability of pulse transformers with suitable inductance.

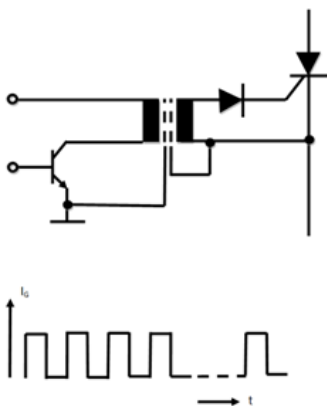

Figure 4. Short pulse picket fence

A chain of short pulses with a frequency in the region of 5kHz to 10kHz is often used. This is sometimes called a “picket fence” waveform.

If the gaps between the pulses cause interference, a second time shifted pulse chain can be superimposed to produce a continuous long pulse. The pulse transformer only has to be dimensioned for a single pulse in the chain, say 50µs to 100µs.

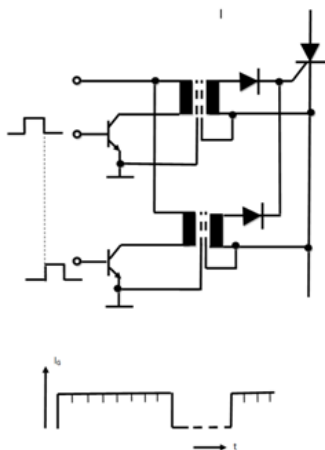

Figure 5. Interleaved pulses

Note that in the above circuits a diode is included between the pulse transformer and the thyristor to eliminate negative gate pulses that are mentioned in the introduction.

Interference

The gate drive is what determines the performance of the equipment. Incorrect firing of the gate drive can lead to disastrous consequences. One of the frequent causes of gate drive misfiring is interference transmitted into the firing circuit from either the power circuit or from the operation of relays and contactors located in close proximity. It is therefore advisable to incorporate components into the output stage of the gate drive to improve noise immunity. These would include the blocking diodes, capacitors and earth screens on the pulse transformers.

The output circuit of the firing circuit

The typical output circuit would therefore include:

- The pulse transformer for circuit isolation
- The resistor to limit the maximum gate current
- The diode, capacitors, and earth screening to prevent spurious triggering.

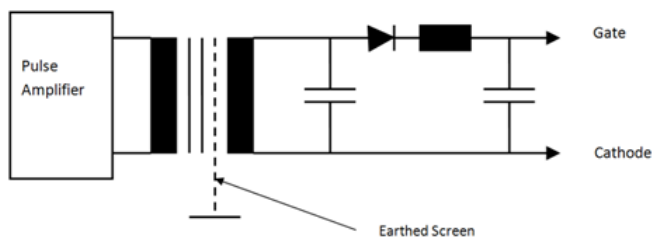

Figure 6. Output of firing circuit

IMPORTANT INFORMATION:

This publication is provided for information only and not for resale.

The products and information in this publication are intended for use by appropriately trained technical personnel.

Due to the diversity of product applications, the information contained herein is provided as a general guide only and does not constitute any guarantee of suitability for use in a specific application. The user must evaluate the suitability of the product and the completeness of the product data for the application. The user is responsible for product selection and ensuring all safety and any warning requirements are met. Should additional product information be needed please contact Customer Service.

Although we have endeavoured to carefully compile the information in this publication it may contain inaccuracies or typographical errors. The information is provided without any warranty or guarantee of any kind.

This publication is an uncontrolled document and is subject to change without notice. When referring to it please ensure that it is the most up to date version and has not been superseded.

The products are not intended for use in applications where a failure or malfunction may cause loss of life, injury or damage to property. The user must ensure that appropriate safety precautions are taken to prevent or mitigate the consequences of a product failure or malfunction.

The products must not be touched when operating because there is a danger of electrocution or severe burning. Always use protective safety equipment such as appropriate shields for the product and wear safety glasses. Even when disconnected any electric charge remaining in the product must be discharged and allowed to cool before safe handling using protective gloves.

Extended exposure to conditions outside the product ratings may affect reliability leading to premature product failure. Use outside the product ratings is likely to cause permanent damage to the product. In extreme conditions, as with all semiconductors, this may include potentially hazardous rupture, a large current to flow or high voltage arcing, resulting in fire or explosion. Appropriate application design and safety precautions should always be followed to protect persons and property.

Product Status & Product Ordering:

We annotate datasheets in the top right-hand corner of the front page, to indicate product status if it is not yet fully approved for production. The annotations are as follows: -

Target Information:	This is the most tentative form of information and represents a very preliminary specification. No actual design work on the product has been started.
Preliminary Information:	The product design is complete and final characterisation for volume production is in progress. The datasheet represents the product as it is now understood but details may change.
No Annotation:	The product has been approved for production and unless otherwise notified by Dynex any product ordered will be supplied to the current version of the data sheet prevailing at the time of our order acknowledgement.

All products and materials are sold and services provided subject to Dynex's conditions of sale, which are available on request.

Any brand names and product names used in this publication are trademarks, registered trademarks or trade names of their respective owners.

HEADQUARTERS OPERATIONS

DYNEX SEMICONDUCTOR LIMITED
Doddington Road, Lincoln, Lincolnshire, LN6 3LF
United Kingdom.
Phone: +44 (0) 1522 500500
Fax: +44 (0) 1522 500550
Web: <http://www.dynexsemi.com>

CUSTOMER SERVICE

Phone: +44 (0) 1522 502753 / 502901
Fax: +44 (0) 1522 500020
e-mail: powersolutions@dynexsemi.com