

AN6143

When I replace obsolete products in my equipment with modern replacements, do I need to replace all the devices in parallel?

Application Note

AN6143-1 January 2014 (LN31287)

Figure 1 shows a simple 3 phase bridge where one thyristor (per arm) is capable of carrying the current that is required to obtain the full output rating of the bridge.

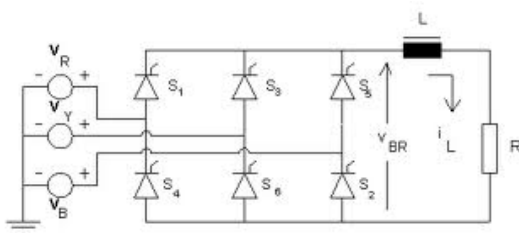

Figure 1. 3phase fully controlled rectifier

If a higher current rating is required then either larger devices are used, if available, or devices are used in parallel. These devices are specially selected to have similar forward voltage drops at the operating current so that they each take approximately the same current. A modern replacement for an obsolete thyristor will not have the same forward voltage drop characteristic and so if it is the only device replaced in multi-parallel device arrangement then it will upset the current sharing. In all probability the modern device will have a lower forward voltage drop at the operating current and so it will take a disproportionate amount of the current and may well burn out. Therefore, in the case where the thyristors S1 to S6 in figure 1 are actually parallel connected thyristors then all the devices in any individual switch (arm) must be of the same type.

Bridges connected in parallel usually have phase shifted inputs to produce a smoother output and are fed from different secondary windings of a transformer. In this way the thyristors in any corresponding arm in each bridge are NOT directly connected in parallel.

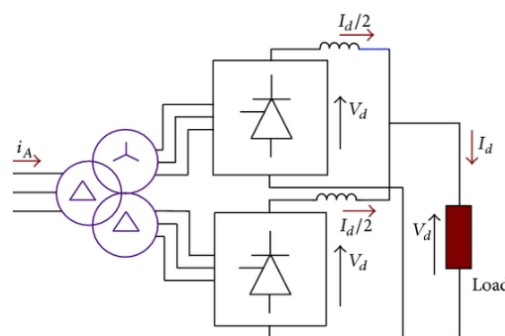

Figure 2. A 12-pulse bridge rectifier consisting of two phase shifted 6 pulse bridges with connected outputs

IMPORTANT INFORMATION:

This publication is provided for information only and not for resale.

The products and information in this publication are intended for use by appropriately trained technical personnel.

Due to the diversity of product applications, the information contained herein is provided as a general guide only and does not constitute any guarantee of suitability for use in a specific application. The user must evaluate the suitability of the product and the completeness of the product data for the application. The user is responsible for product selection and ensuring all safety and any warning requirements are met. Should additional product information be needed please contact Customer Service.

Although we have endeavoured to carefully compile the information in this publication it may contain inaccuracies or typographical errors. The information is provided without any warranty or guarantee of any kind.

This publication is an uncontrolled document and is subject to change without notice. When referring to it please ensure that it is the most up to date version and has not been superseded.

The products are not intended for use in applications where a failure or malfunction may cause loss of life, injury or damage to property. The user must ensure that appropriate safety precautions are taken to prevent or mitigate the consequences of a product failure or malfunction.

The products must not be touched when operating because there is a danger of electrocution or severe burning. Always use protective safety equipment such as appropriate shields for the product and wear safety glasses. Even when disconnected any electric charge remaining in the product must be discharged and allowed to cool before safe handling using protective gloves.

Extended exposure to conditions outside the product ratings may affect reliability leading to premature product failure. Use outside the product ratings is likely to cause permanent damage to the product. In extreme conditions, as with all semiconductors, this may include potentially hazardous rupture, a large current to flow or high voltage arcing, resulting in fire or explosion. Appropriate application design and safety precautions should always be followed to protect persons and property.

Product Status & Product Ordering:

We annotate datasheets in the top right-hand corner of the front page, to indicate product status if it is not yet fully approved for production. The annotations are as follows: -

Target Information:	This is the most tentative form of information and represents a very preliminary specification. No actual design work on the product has been started.
Preliminary Information:	The product design is complete and final characterisation for volume production is in progress. The datasheet represents the product as it is now understood but details may change.
No Annotation:	The product has been approved for production and unless otherwise notified by Dynex any product ordered will be supplied to the current version of the data sheet prevailing at the time of our order acknowledgement.

All products and materials are sold and services provided subject to Dynex's conditions of sale, which are available on request.

Any brand names and product names used in this publication are trademarks, registered trademarks or trade names of their respective owners.

HEADQUARTERS OPERATIONS

DYNEX SEMICONDUCTOR LIMITED
Doddington Road, Lincoln, Lincolnshire, LN6 3LF
United Kingdom.
Phone: +44 (0) 1522 500500
Fax: +44 (0) 1522 500550
Web: <http://www.dynexsemi.com>

CUSTOMER SERVICE

Phone: +44 (0) 1522 502753 / 502901
Fax: +44 (0) 1522 500020
e-mail: powersolutions@dynexsemi.com