



# DS2904SM28

## Rectifier Diode Preliminary Information

DS5869-2.0 January 2010 (LN26975)

### FEATURES

- Double Side Cooling
- High Surge Capability

### APPLICATIONS

- Rectification
- Free-wheel Diode
- DC Motor Control
- Power Supplies
- Welding
- Battery Chargers

### VOLTAGE RATINGS

Part and Ordering Number	Repetitive Peak Voltages $V_{DRM}$ and $V_{DRM}$ V	Conditions
DS2904SM28	2800	$T_{vj} = -40^{\circ}\text{C}$ to $160^{\circ}\text{C}$ , $I_{RRM} = 200\text{mA}$ , $V_{RRM} t_p = 10\text{ms}$ , $V_{RSM} = V_{RRM} + 100\text{V}$ respectively
DS2904SM26	2600	
DS2904SM24	2400	

Lower voltage grades available.

### ORDERING INFORMATION

When ordering, select the required part number shown in the Voltage Ratings selection table.

For example:

**DS2904SM26** for a 2600V device

Note: Please use the complete part number when ordering and quote this number in any future correspondence relating to your order.

### KEY PARAMETERS

$V_{RRM}$	<b>2800V</b>
$I_{F(AV)}$	<b>8790A</b>
$I_{FSM}$	<b>95000A</b>

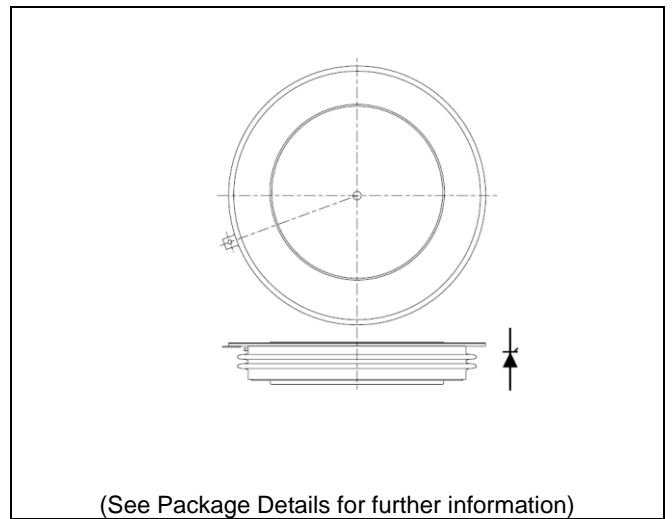

Fig. 1 Package outline M

**CURRENT RATINGS**

T<sub>case</sub> = 75°C unless stated otherwise

Symbol	Parameter	Test Conditions	Max.	Units
<b>Double Side Cooled</b>				
I <sub>F(AV)</sub>	Mean forward current	Half wave resistive load	8790	A
I <sub>F(RMS)</sub>	RMS value	-	13800	A
I <sub>F</sub>	Continuous (direct) on-state current	-	12777	A
<b>Single Side Cooled (Anode side)</b>				
I <sub>F(AV)</sub>	Mean forward current	Half wave resistive load	5765	A
I <sub>F(RMS)</sub>	RMS value	-	9056	A
I <sub>F</sub>	Continuous (direct) on-state current	-	7698	A

T<sub>case</sub> = 100°C unless stated otherwise

Symbol	Parameter	Test Conditions	Max.	Units
<b>Double Side Cooled</b>				
I <sub>F(AV)</sub>	Mean forward current	Half wave resistive load	6992	A
I <sub>F(RMS)</sub>	RMS value	-	10984	A
I <sub>F</sub>	Continuous (direct) on-state current	-	9942	A
<b>Single Side Cooled (Anode side)</b>				
I <sub>F(AV)</sub>	Mean forward current	Half wave resistive load	4507	A
I <sub>F(RMS)</sub>	RMS value	-	7079	A
I <sub>F</sub>	Continuous (direct) on-state current	-	5857	A

**SURGE RATINGS**

Symbol	Parameter	Test Conditions	Max.	Units
$I_{FSM}$	Surge (non-repetitive) on-state current	10ms half sine, $T_{case} = 150^{\circ}C$ $V_R = 50\% V_{RRM} - \frac{1}{4}$ sine	76.0	kA
$I^2t$	$I^2t$ for fusing		28.9	$MA^2s$
$I_{FSM}$	Surge (non-repetitive) on-state current	10ms half sine, $T_{case} = 150^{\circ}C$ $V_R = 0$	95.0	kA
$I^2t$	$I^2t$ for fusing		45.1	$MA^2s$

**THERMAL AND MECHANICAL RATINGS**

Symbol	Parameter	Test Conditions		Min.	Max.	Units
$R_{th(j-c)}$	Thermal resistance – junction to case	Double side cooled	DC	-	0.00558	$^{\circ}C/W$
		Single side cooled	Anode DC	-	0.01115	$^{\circ}C/W$
			Cathode DC	-	0.01115	$^{\circ}C/W$
$R_{th(c-h)}$	Thermal resistance – case to heatsink	Clamping force 54kN (with mounting compound)	Double side	-	0.00113	$^{\circ}C/W$
			Single side	-	0.00226	$^{\circ}C/W$
$T_{vj}$	Virtual junction temperature	On-state (conducting)		-	170	$^{\circ}C$
		Reverse (blocking)		-	160	$^{\circ}C$
$T_{stg}$	Storage temperature range			-55	160	$^{\circ}C$
$F_m$	Clamping force			75	91	kN

**CHARACTERISTICS**

Symbol	Parameter	Test Conditions	Min.	Max.	Units
$V_{FM}$	Forward voltage	At 3000A peak, $T_{case} = 25^{\circ}C$	-	0.97	V
$I_{RM}$	Peak reverse current	At $V_{DRM}$ , $T_{case} = 160^{\circ}C$	-	200	mA
$Q_S$	Total stored charge	$I_F = 2000A$ , $dI_{RR}/dt = 3A/\mu s$ $T_{case} = 150^{\circ}C$ , $V_R > 300V$	-	3900	$\mu C$
$I_{rr}$	Peak reverse recovery current		-	115	A
$V_{TO}$	Low Level Threshold voltage	At $150^{\circ}C$ , 1000A to 3200A	-	0.6364	V
	High Level Threshold voltage	At $150^{\circ}C$ , 3200A to 8000A	-	0.6909	V
$r_T$	Low Level Slope resistance	At $150^{\circ}C$ , 1000A to 3200A	-	0.056	$m\Omega$
	High Level Slope resistance	At $150^{\circ}C$ , 3200A to 8000A	-	0.0389	$m\Omega$

**CURVES**

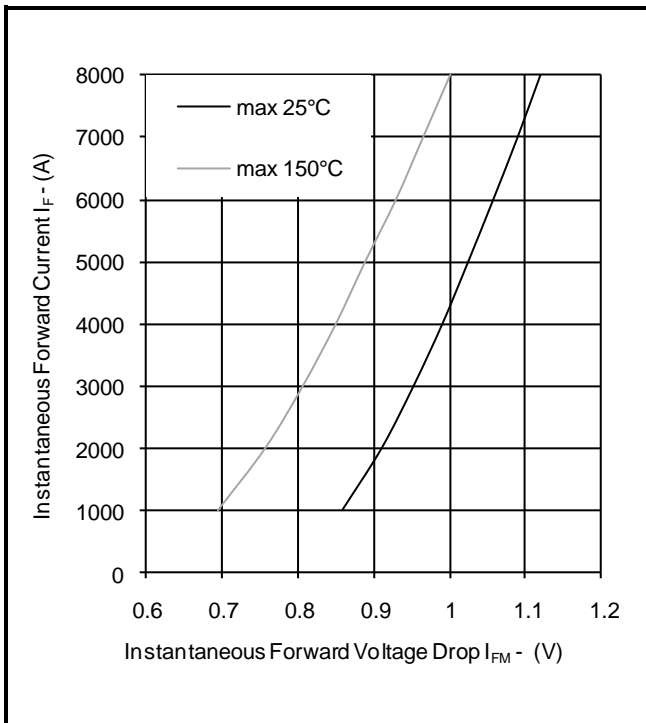

**Fig.2 Maximum & minimum on-state characteristics**

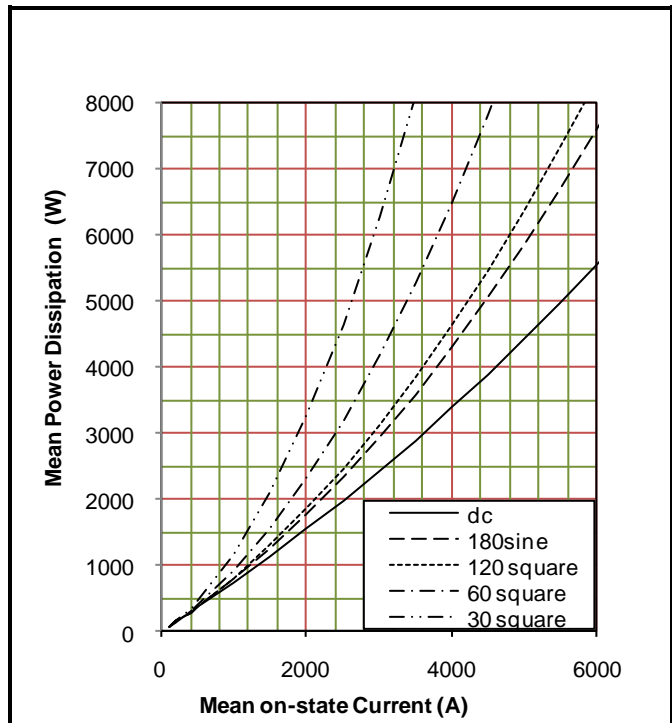

**Fig.3 Dissipation curves**

**$V_{TM}$  EQUATION**

$$V_{TM} = A + B \ln(I_T) + C \cdot I_T + D \cdot \sqrt{I_T}$$

Where  $A = 0.419759$   
 $B = 0.029383$   
 $C = 0.000023$   
 $D = 0.001492$

these values are valid for  $T_j = 150^{\circ}C$  for  $I_T$  1000A to 8000A

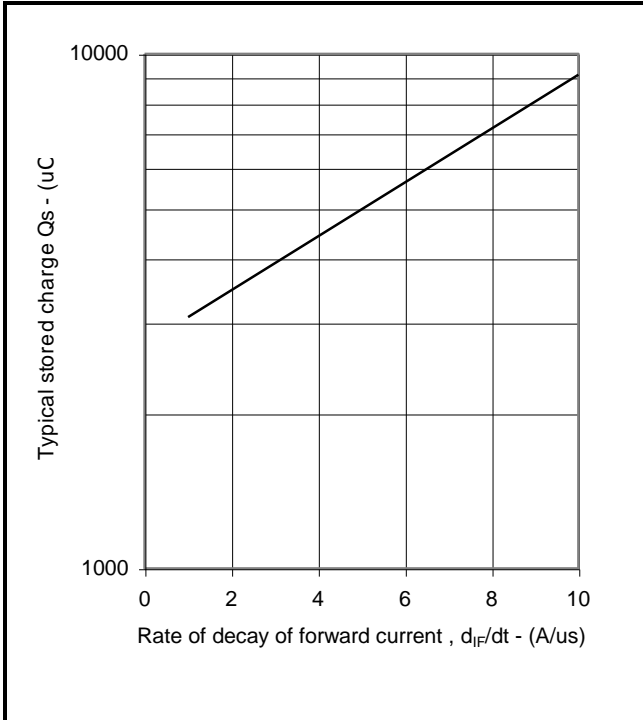

Fig.4 Total stored charge

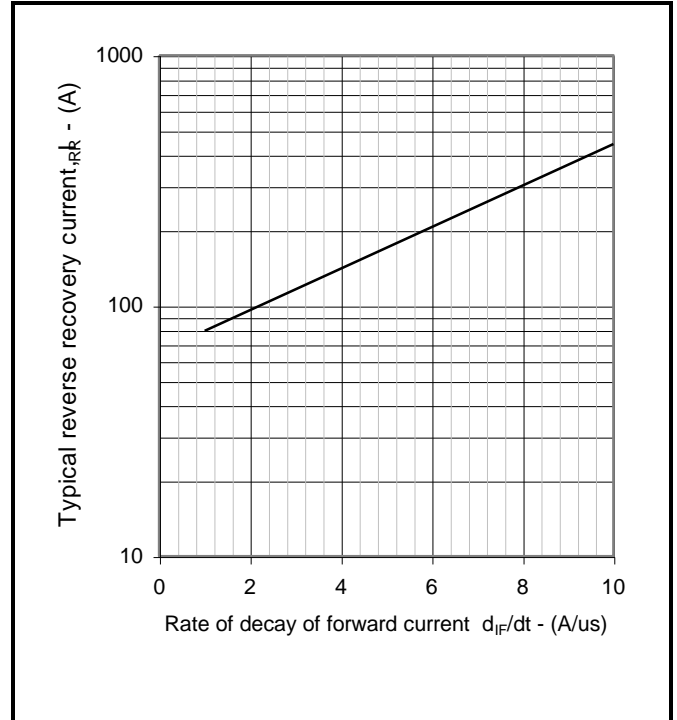

Fig.5 Maximum reverse recovery current

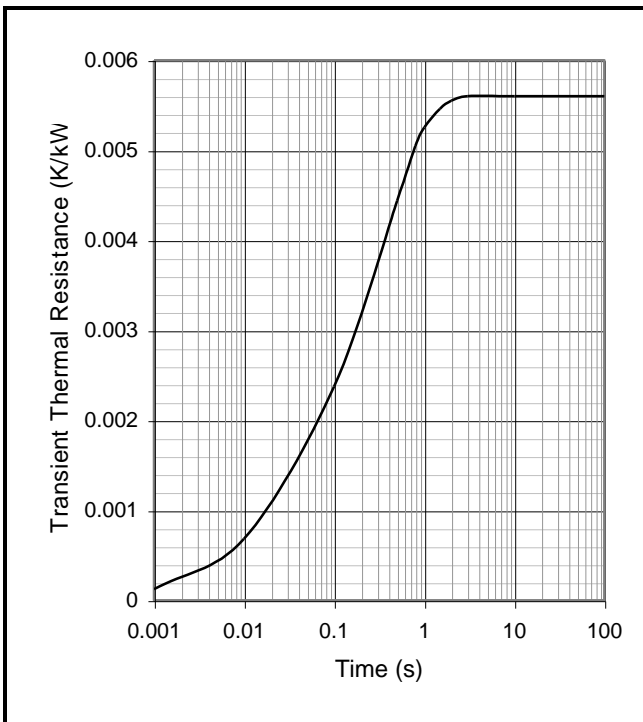

Fig.6 Maximum (limit) transient thermal impedance-junction to case

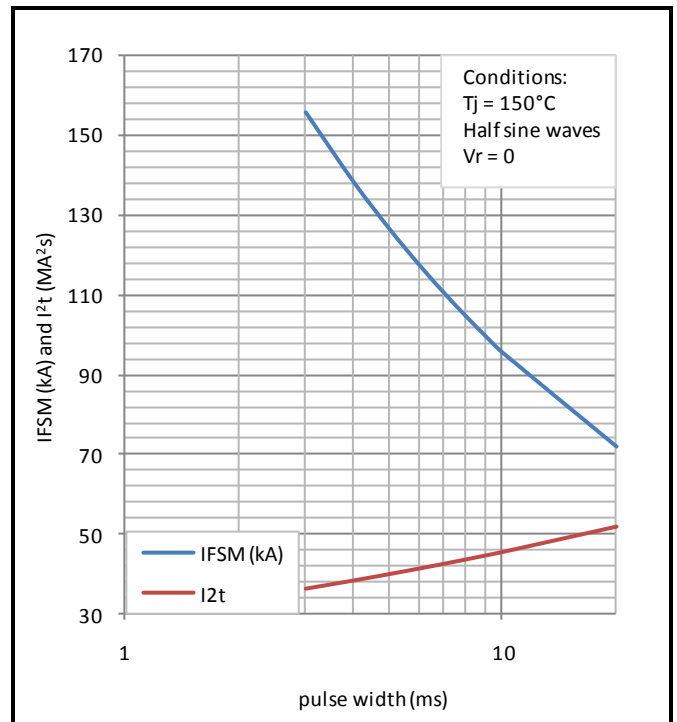
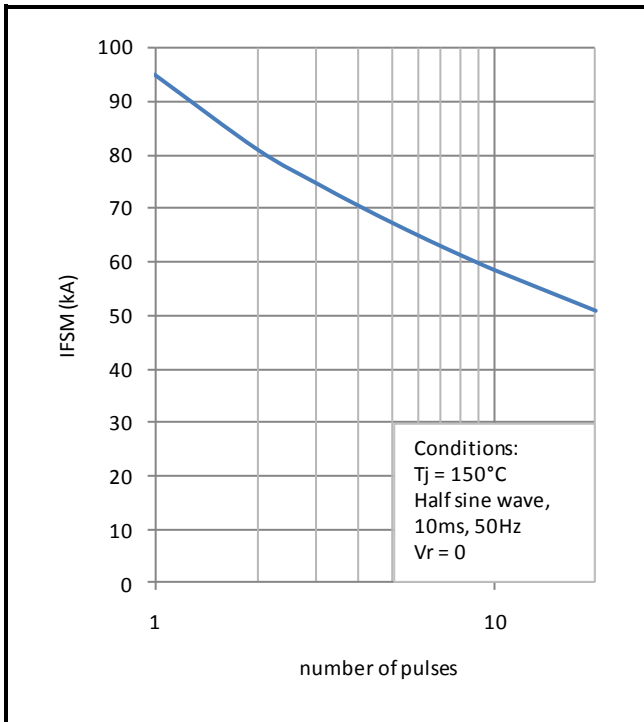

Fig.7 Single cycle surge



**Fig.8 Multi-cycle surge**

**PACKAGE DETAILS**

For further package information, please contact Customer Services. All dimensions in mm, unless stated otherwise. DO NOT SCALE.

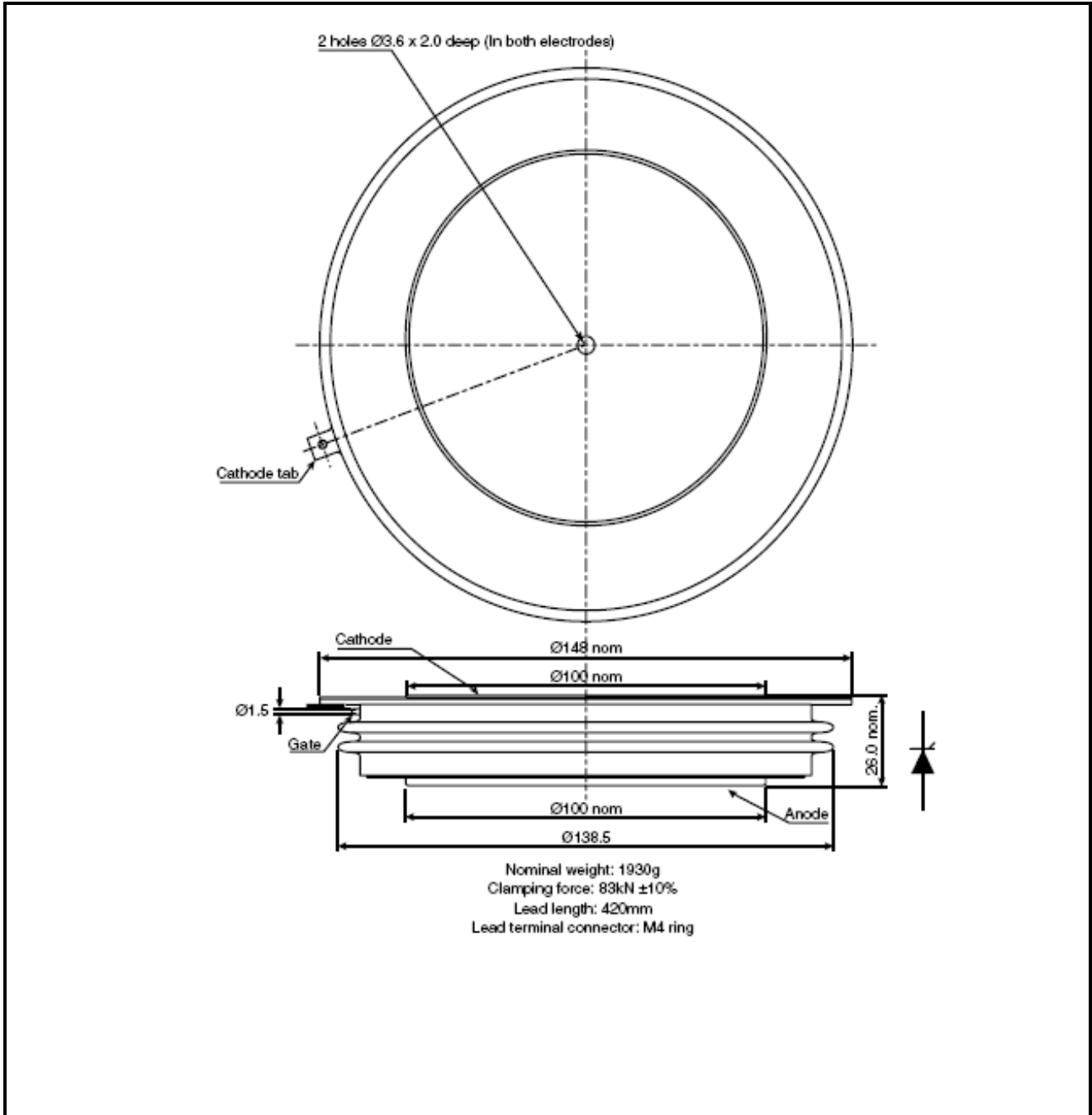

**Figure 8 Package outline code M**

**Note:**

Some packages may be supplied with gate and or tags.

Stresses above those listed in this data sheet may cause permanent damage to the device. In extreme conditions, as with all semiconductors, this may include potentially hazardous rupture of the package. Appropriate safety precautions should always be followed.

## HEADQUARTERS OPERATIONS

DYNEX SEMICONDUCTOR LIMITED  
Doddington Road, Lincoln, Lincolnshire, LN6 3LF  
United Kingdom.  
Phone: +44 (0) 1522 500500  
Fax: +44 (0) 1522 500550  
Web: <http://www.dynexsemi.com>

## CUSTOMER SERVICE

Phone: +(0) 1522 502753 / 502901  
Fax: +(0) 1522 500020  
e-mail: [power\\_solutions@dynexsemi.com](mailto:power_solutions@dynexsemi.com)

© Dynex Semiconductor 2003 TECHNICAL DOCUMENTATION – NOT FOR RESALE. PRODUCED IN UNITED KINGDOM.

This publication is issued to provide information only which (unless agreed by the Company in writing) may not be used, applied or reproduced for any purpose nor form part of any order or contract nor to be regarded as a representation relating to the products or services concerned. No warranty or guarantee express or implied is made regarding the capability, performance or suitability of any product or service. The Company reserves the right to alter without prior notice the specification, design or price of any product or service. Information concerning possible methods of use is provided as a guide only and does not constitute any guarantee that such methods of use will be satisfactory in a specific piece of equipment. It is the user's responsibility to fully determine the performance and suitability of any equipment using such information and to ensure that any publication or data used is up to date and has not been superseded. These products are not suitable for use in any medical products whose failure to perform may result in significant injury or death to the user. All products and materials are sold and services provided subject to the Company's conditions of sale, which are available on request.

All brand names and product names used in this publication are trademarks, registered trademarks or trade names of their respective owners.