

The MA9264 64k Static RAM is configured as 8192x8 bits and manufactured using CMOS-SOS high performance, radiation hard, 1.5µm technology.

The design uses a 6 transistor cell and has full static operation with no clock or timing strobe required. Address input buffers are deselected when chip select is in the HIGH state.

See Application Note "Overview of the Dynex Semiconductor Radiation Hard 1.5µm CMOS/SOS SRAM Range".

FEATURES

- 1.5µm CMOS-SOS Technology
- Latch-up Free
- Fast Access Time 70ns Typical
- Total Dose 10⁶ Rad(Si)
- Transient Upset >10¹¹ Rad(Si)/sec
- SEU 4.3 x 10⁻¹¹ Errors/bitday
- Single 5V Supply
- Three State Output
- Low Standby Current 100µA Typical
- -55°C to +125°C Operation
- All Inputs and Outputs Fully TTL or CMOS Compatible
- Fully Static Operation

Operation Mode	\overline{CS}	CE	\overline{OE}	\overline{WE}	I/O	Power
Read	L	H	L	H	D OUT	ISB1
Write	L	H	X	L	D IN	
Output Disable	L	H	H	H	High Z	
Standby	H	X	X	X	High Z	ISB2
	X	L	X	X	X	

Figure 1: Truth Table

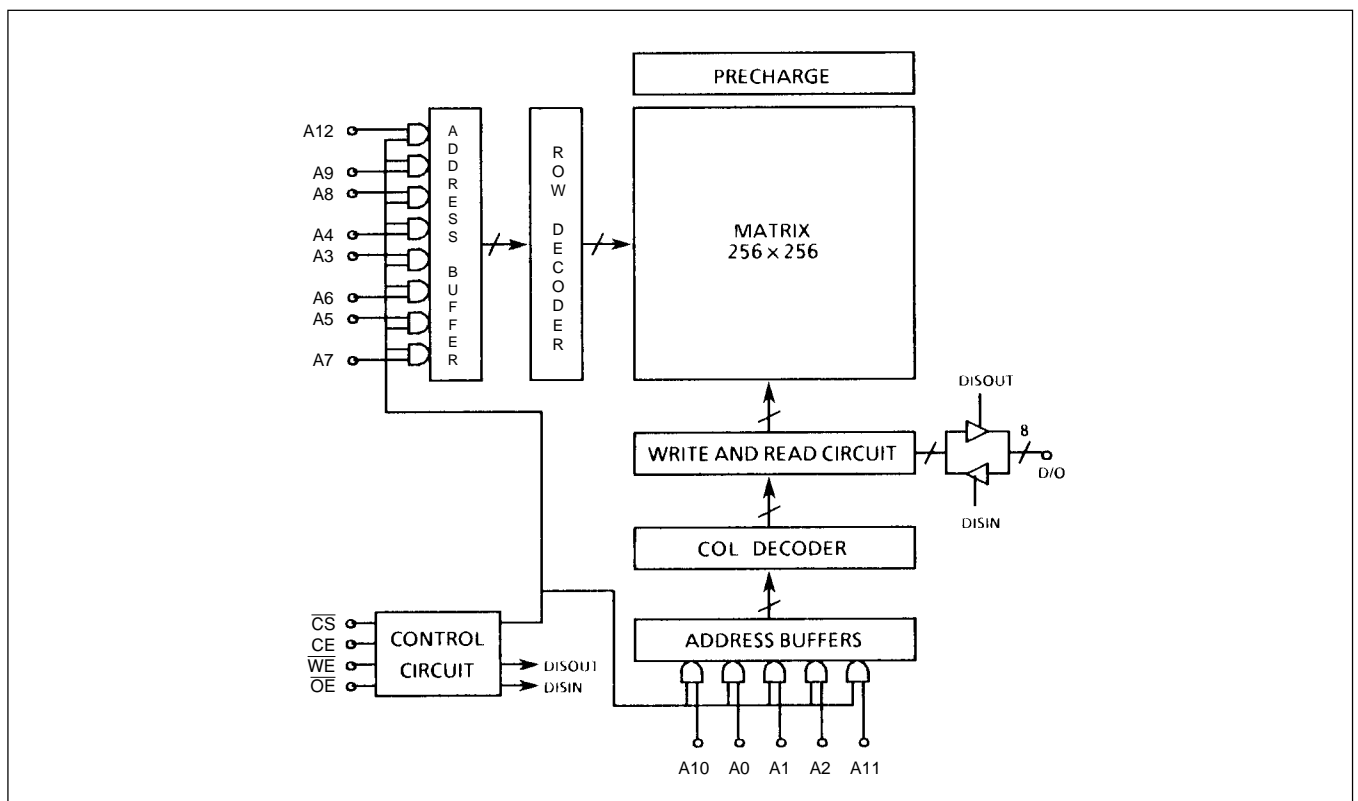

Figure 2: Block Diagram

MA9264

SIGNAL DEFINITIONS

A0-12

Address input pins which select a particular eight bit word within the memory array.

D0-7

Bidirectional data pins which serve as data outputs during a read operation and as data inputs during a write operation.

$\overline{\text{CS}}$

Chip Select, which, at low level, activates a read or write operation. When at a high level it defaults the SRAM to a precharge condition and holds the data output drivers in a high impedance state.

$\overline{\text{WE}}$

Write Enable which when at a low level enables a write and holds data output drivers in a high impedance state. When at a high level, it enables a read.

$\overline{\text{OE}}$

Output Enable which when at a high level holds the data output drivers in a high impedance state. When at a low level, data output driver state is defined by $\overline{\text{CS}}$, $\overline{\text{WE}}$ and CE. If this signal is not used it must be connected to VSS.

CE

Chip Enable which when at a high level allows normal operation. When at a low level it defaults the SRAM to a precharge condition, disables the input circuits on all input pins and holds the data output drivers in a high impedance state. If this signal is not used it must be connected to VDD.

CHARACTERISTICS AND RATINGS

Symbol	Parameter	Min.	Max.	Units
V_{CC}	Supply Voltage	-0.5	7.0	V
V_I	Input Voltage	-0.3	$V_{DD}+0.3$	V
T_A	Operating Temperature	-55	125	°C
T_S	Storage Temperature	-65	150	°C

Stresses above those listed may cause permanent damage to the device. This is a stress rating only and functional operation of the device at these conditions, or at any other condition above those indicated in the operations section of this specification, is not Implied. Exposure to absolute maximum rating conditions for extended periods may affect device reliability.

Figure 3: Absolute Maximum Ratings

Notes for Tables 4 and 5:

Characteristics apply to pre radiation at $T_A = -55^{\circ}\text{C}$ to $+125^{\circ}\text{C}$ with $V_{DD} = 5\text{V} \pm 10\%$ and to post 100k Rad(Si) total dose radiation at $T_A = 25^{\circ}\text{C}$ with $V_{DD} = 5\text{V} \pm 10\%$ (characteristics at higher radiation levels available on request). GROUP A SUBGROUPS 1, 2, 3.

Symbol	Parameter	Conditions	(Option)	Min.	Typ.	Max.	Units
V_{DD}	Supply voltage	-		4.5	5.0	5.5	V
V_{IH}	Logical '1' Input Voltage	-	(TTL) (CMOS)	$V_{DD}/2$ $0.8 V_{DD}$	- -	V_{DD} V_{DD}	V V
V_{IL}	Logical '0' Input Voltage	-	(TTL) (CMOS)	V_{SS} V_{SS}	- -	0.8 $0.2 V_{DD}$	V V
V_{OH1}	Logical '1' Output Voltage	$I_{OH1} = -2\text{mA}$		2.4	-	-	V
V_{OH2}	Logical '1' Output Voltage	$I_{OH2} = -1\text{mA}$		$V_{DD}-0.5$	-	-	V
V_{OL}	Logical '0' Output Voltage	$I_{OL} = 4\text{mA}$		-	-	0.4	V
I_{LI}	Input Leakage Current	$V_{IN} = V_{DD}$ or V_{SS}	All inputs	-	-	± 10	μA
I_{LO}	Output Leakage Current	Chip disabled, $V_{OUT} = V_{DD}$ or V_{SS}		-	-	± 10	μA
I_{SB1}	Selected Static Current (CMOS)	All inputs = $V_{DD}-0.2\text{V}$ except $\overline{CS} = V_{SS}+0.2\text{V}$		-	0.1	10	mA
I_{DD}	Dynamic Operating Current (CMOS)	$f_{RC} = 1\text{MHz}$, all inputs switching, $V_{IH} = V_{DD}-0.2\text{V}$		-	6	18	mA
I_{SB2}	Standby Supply Current	$\overline{CS} = V_{DD}-0.2\text{V}$ $CE = V_{SS}+0.2\text{V}$		-	0.1	10	mA

Figure 4: Electrical Characteristics

Symbol	Parameter	Conditions	(Option)	Min.	Typ.	Max.	Units
V_{DR}	V_{CC} for Data Retention	$\overline{CS} = V_{DR}$, $CE = V_{SS}$		2.0	-	-	V
I_{DDR}	Data Retention Current	$\overline{CS} = V_{DR}$, $V_{DR} = 2.0\text{V}$ $CE = V_{SS}$		-	0.05	4	mA

Figure 5: Data Retention Characteristics

MA9264

AC CHARACTERISTICS

Conditions of Test for Tables 5 and 6:

1. Input pulse = V_{SS} to 3.0V (TTL) and V_{SS} to 4.0V (CMOS).
2. Times measurement reference level = 1.5V.
3. Input Rise and Fall times ≤ 5 ns.
4. Output load 1TTL gate and $CL = 60$ pF.
5. Transition is measured at ± 500 mV from steady state.
6. This parameter is sampled and not 100% tested.

Notes for Tables 6 and 7:

Characteristics apply to pre-radiation at $T_A = -55^\circ\text{C}$ to $+125^\circ\text{C}$ with $V_{DD} = 5V \pm 10\%$ and to post 100k Rad(Si) total dose radiation at $T_A = 25^\circ\text{C}$ with $V_{DD} = 5V \pm 10\%$. GROUP A SUBGROUPS 9, 10, 11.

Symbol	Parameter	MAX9264X70		MAX9264X95		Units
		Min	Max	Min	Max	
T_{AVAVR}	Read Cycle Time	70	-	95	-	ns
T_{AVQV}	Address Access Time	-	65	-	90	ns
T_{EHQV}	Chip Select Access Time	-	70	-	95	ns
T_{SLQV}	Chip Enable Access Time	-	70	-	95	ns
T_{EHQX} (5,6)	Chip Selection to Output in Low Z	15	-	15	-	ns
T_{SLQX} (5,6)	Chip Enable to Output in Low Z	15	-	15	-	ns
T_{ELQZ} (5,6)	Chip Deselection to Output in High Z	0	20	0	20	ns
T_{SHQZ} (5,6)	Chip Disable to Output in High Z	0	20	0	20	ns
T_{AXQX}	Output Hold from Address Change	30	-	40	-	ns
T_{GLQV}	Output Enable Access Time	-	25	-	30	ns
T_{GLQX} (5,6)	Output Enable to Output in Low Z	15	-	15	-	ns
T_{GHQZ} (5,6)	Output Enable to Output in High Z	0	20	0	20	ns

Figure 6: Read Cycle AC Electrical Characteristics

Symbol	Parameter	MAX9264X70		MAX9264X95		Units
		Min	Max	Min	Max	
T_{AVAVW}	Write Cycle Time	55	-	60	-	ns
T_{EHW}	Chip Selection to End of Write	50	-	60	-	ns
T_{SLWH}	Chip Enable to End of Write	50	-	60	-	ns
T_{AVWH}	Address Valid to End of Write	50	-	55	-	ns
T_{AVWL}	Address Set Up Time	0	-	0	-	ns
T_{WLWH}	Write Pulse Width	40	-	45	-	ns
T_{WHAV}	Write Recovery Time	0	-	0	-	ns
T_{WLQZ} (5,6)	Write to Output in High Z	0	20	0	20	ns
T_{DVWH}	Data to Write Time Overlap	25	-	30	-	ns
T_{WHDX}	Data Hold from Write	0	-	0	-	ns
T_{WHQX} (5,6)	Output Active from End to Write	0	20	0	20	ns

Figure 7: Write Cycle AC Electrical Characteristics

Symbol	Parameter	Conditions	Min.	Typ.	Max.	Units
C_{IN}	Input Capacitance	$V_I = 0V$	-	3	5	pF
C_{OUT}	Output Capacitance	$V_{IO} = 0V$	-	5	7	pF

Note: $T_A = 25^\circ C$ and $f = 1MHz$. Data obtained by characterisation or analysis; not routinely measured.

Figure 8: Capacitance

Symbol	Parameter	Conditions
F_T	Basic Functionality	$V_{DD} = 4.5V - 5.5V$, FREQ = 1MHz $V_{IL} = V_{SS}$, $V_{IH} = V_{DD}$, $V_{OL} \leq 1.5V$, $V_{OH} \geq 1.5V$ TEMP = $-55^\circ C$ to $+125^\circ C$, GPS PATTERN SET GROUP A SUBGROUPS 7, 8A, 8B

Figure 9: Functionality

Subgroup	Definition
1	Static characteristics specified in Tables 4 and 5 at $+25^\circ C$
2	Static characteristics specified in Tables 4 and 5 at $+125^\circ C$
3	Static characteristics specified in Tables 4 and 5 at $-55^\circ C$
7	Functional characteristics specified in Table 9 at $+25^\circ C$
8A	Functional characteristics specified in Table 9 at $+125^\circ C$
8B	Functional characteristics specified in Table 9 at $-55^\circ C$
9	Switching characteristics specified in Tables 6 and 7 at $+25^\circ C$
10	Switching characteristics specified in Tables 6 and 7 at $+125^\circ C$
11	Switching characteristics specified in Tables 6 and 7 at $-55^\circ C$

Figure 10: Definition of Subgroups

TIMING DIAGRAMS

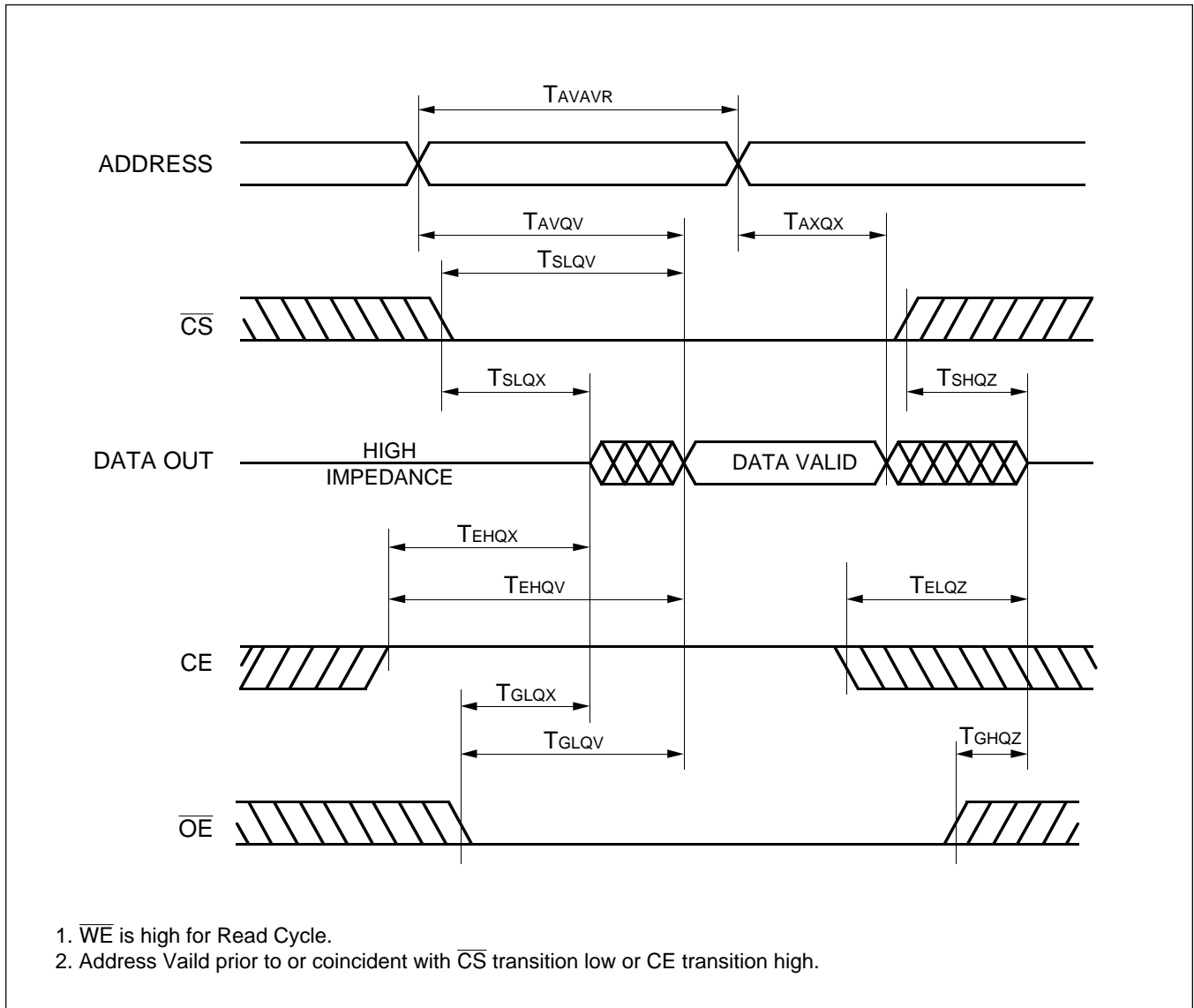

Figure 11a: Read Cycle 1

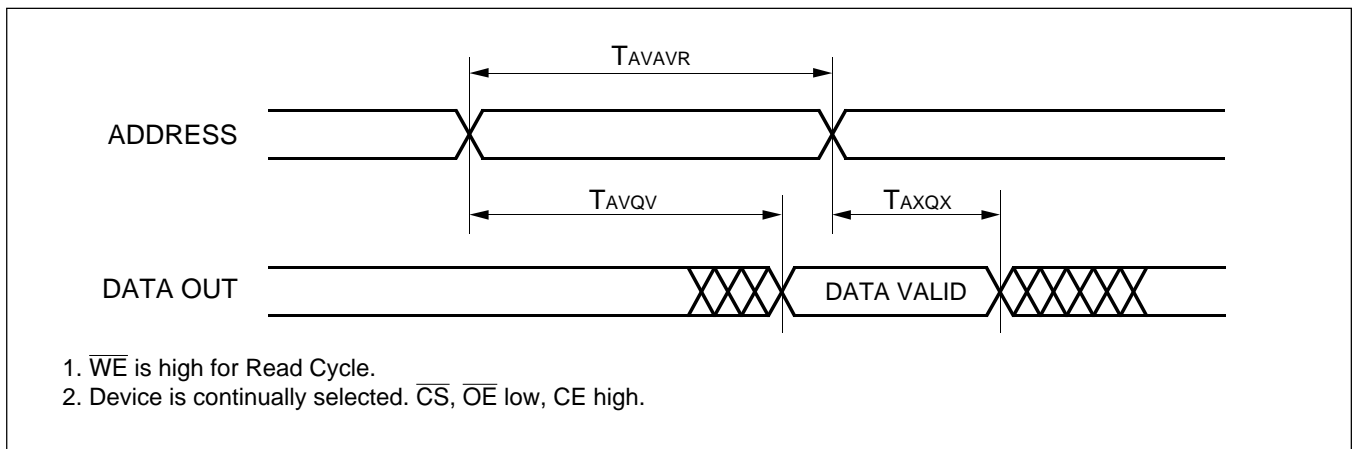
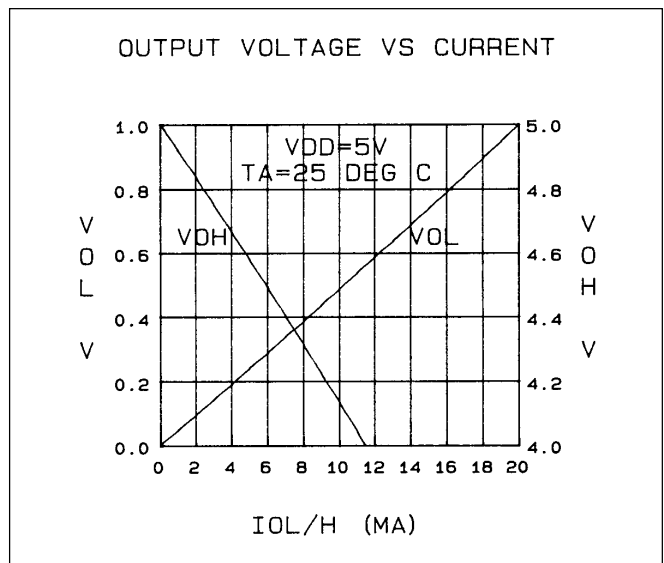
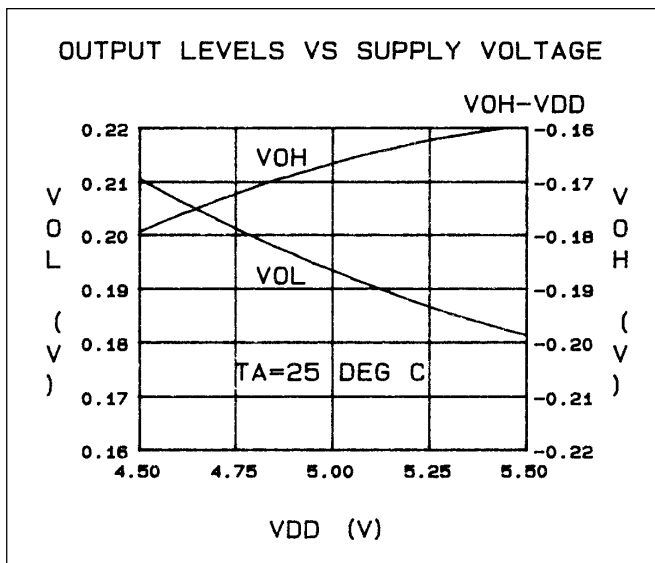
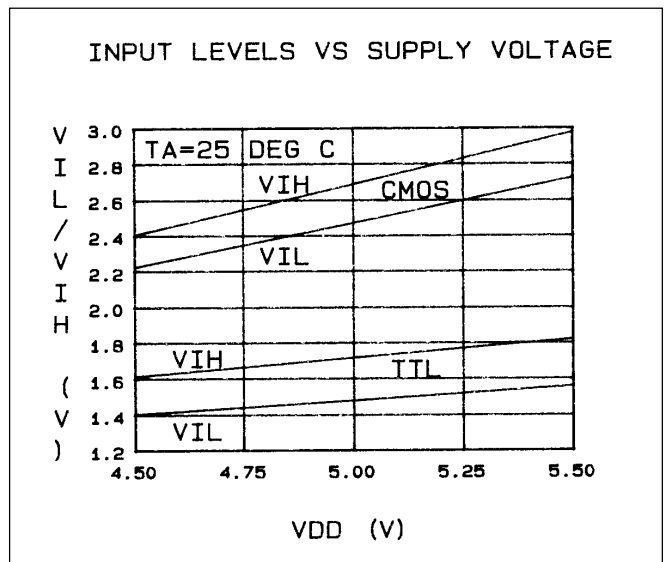
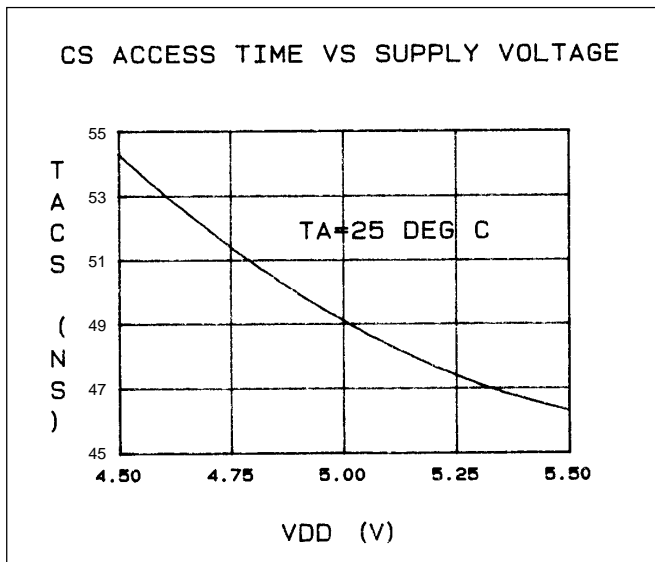
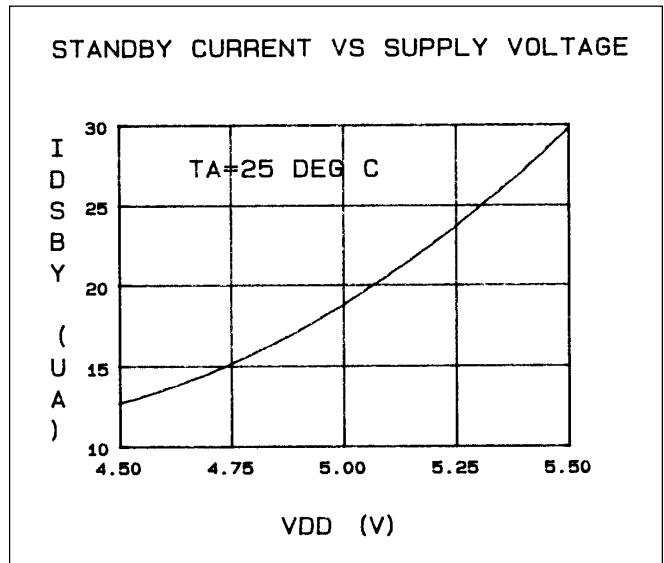
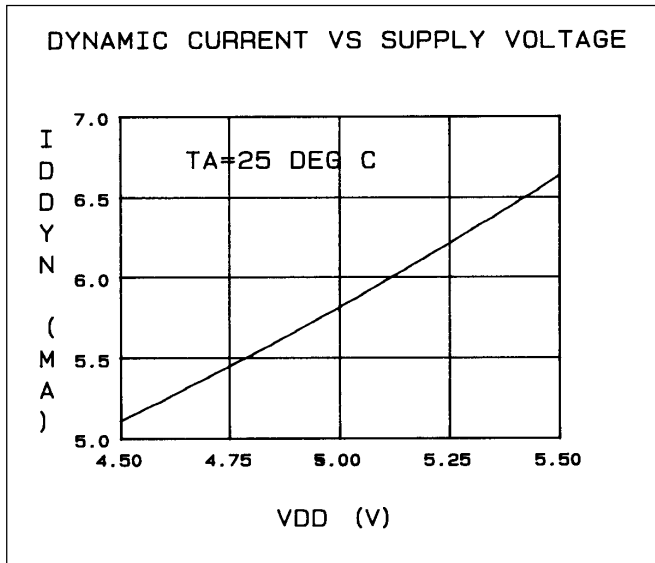
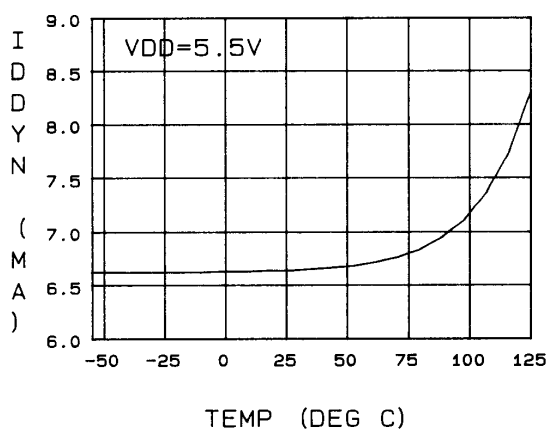

Figure 11b: Read Cycle 2

TYPICAL PERFORMANCE CHARACTERISTICS MAx9264x70



DYNAMIC CURRENT VS TEMPERATURE



STANDBY CURRENT VS TEMPERATURE

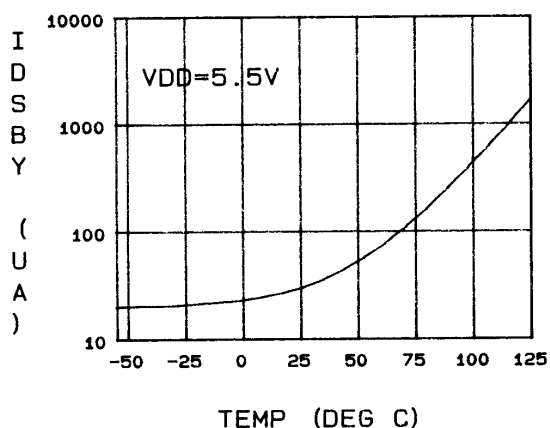

CS ACCESS TIME VS TEMPERATURE

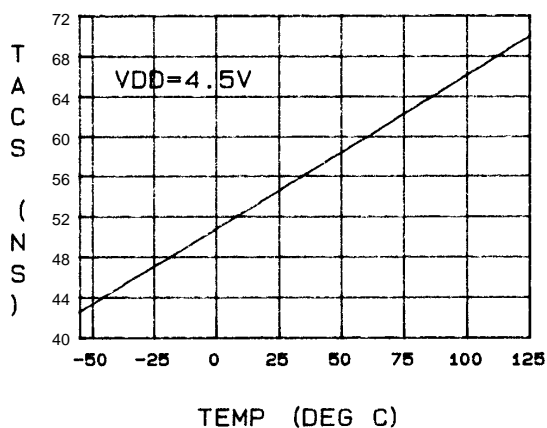

INPUT LEVELS VS TEMPERATURE

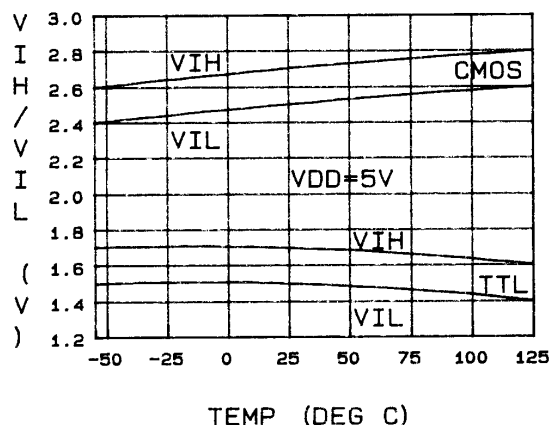

OUTPUT LEVELS VS TEMPERATURE

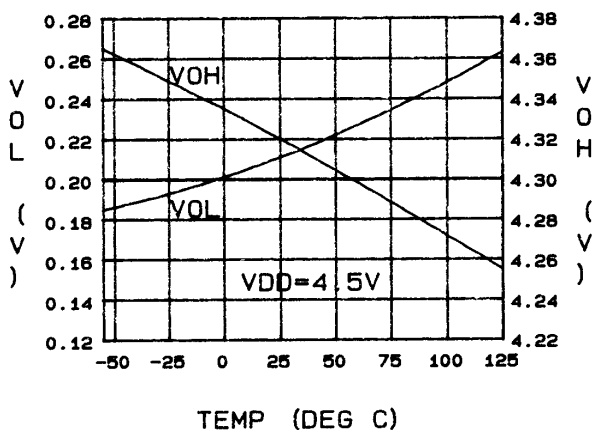

CS ACCESS TIME VS OUTPUT LOAD

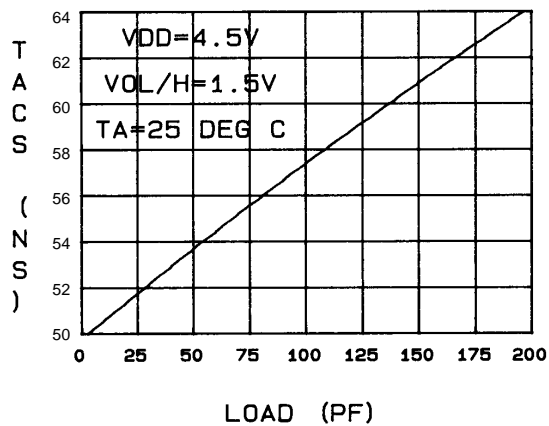

DYNAMIC CURRENT VS RADIATION

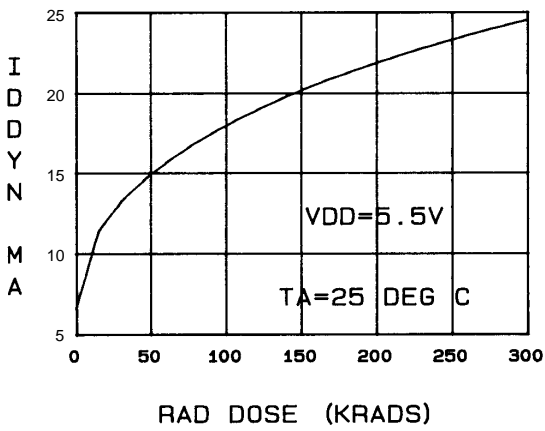

STANDBY CURRENT VS RADIATION

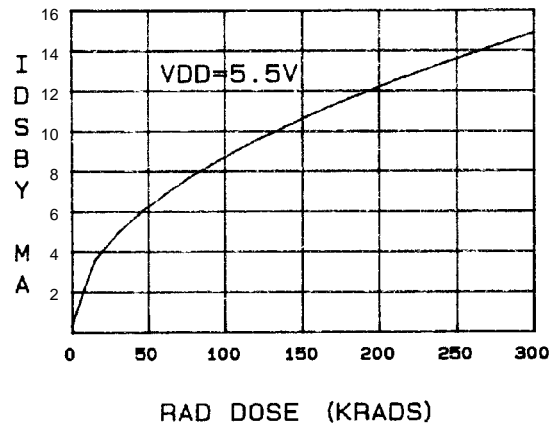

CS ACCESS TIME VS RADIATION

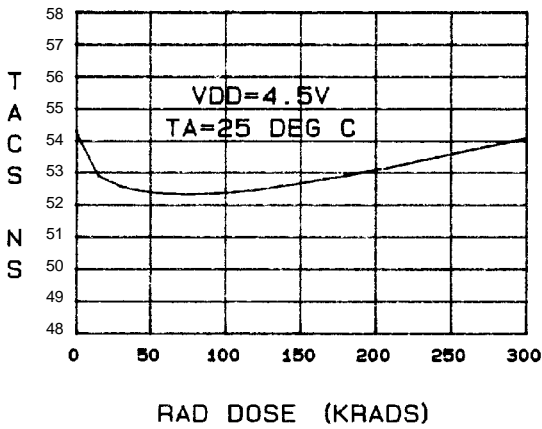

INPUT LEVELS VS RADIATION

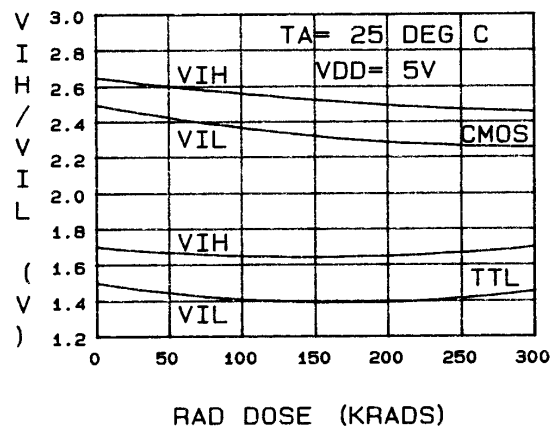

OUTPUT LEVELS VS RADIATION

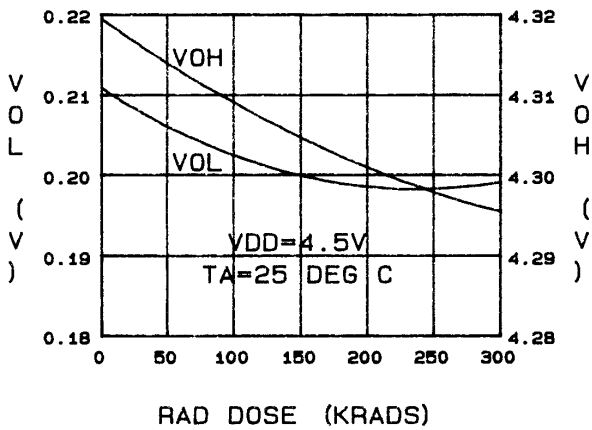

DYNAMIC CURRENT VS FREQUENCY

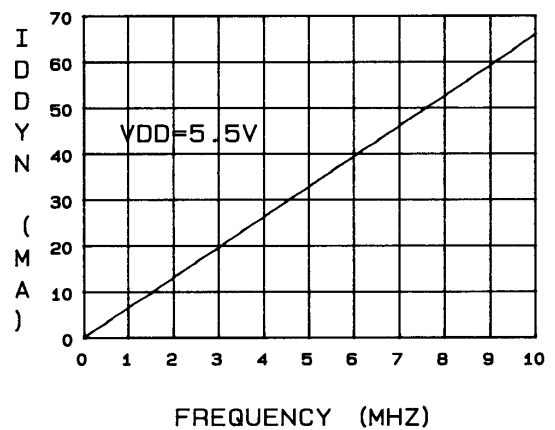

OUTLINES AND PIN ASSIGNMENTS

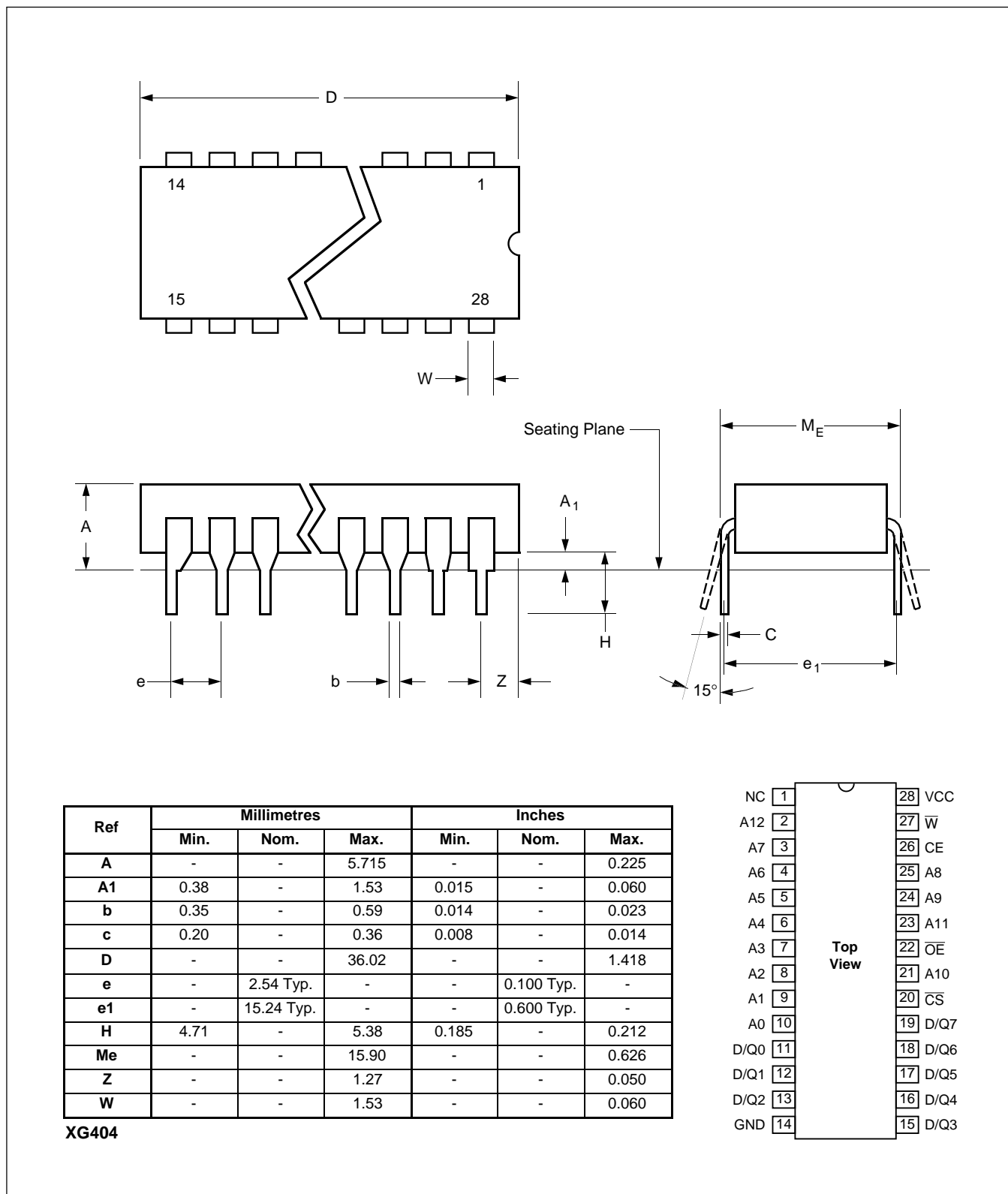
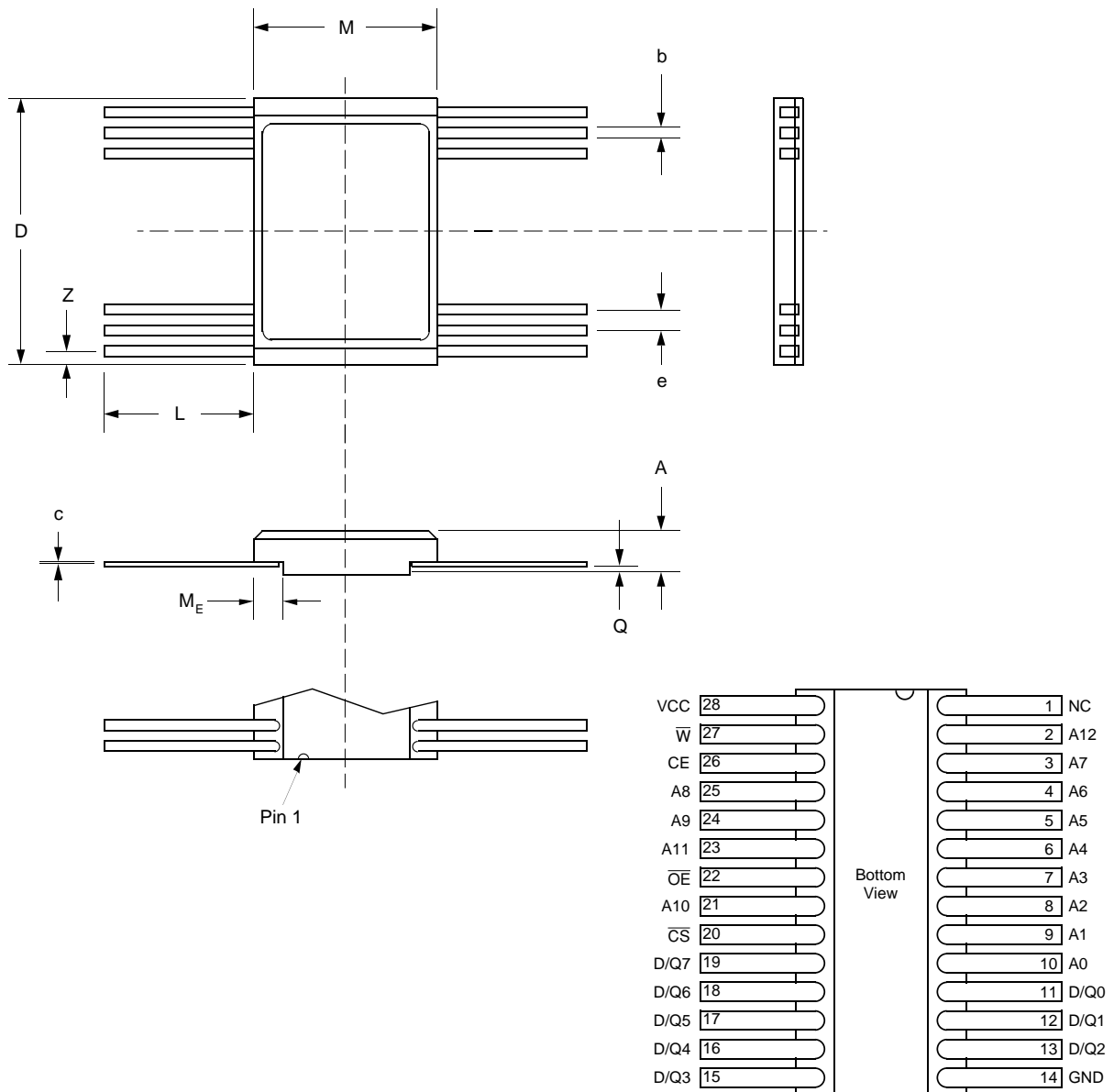

Figure 13: 28-Lead Ceramic DIL (Solder Seal) - Package Style C



Ref	Millimetres			Inches		
	Min.	Nom.	Max.	Min.	Nom.	Max.
A	-	-	3.18	-	-	0.125
Q	0.66	-	-	0.026	-	-
b	0.38	-	0.48	0.015	-	0.019
c	0.10	-	0.18	0.004	-	0.007
D	18.08	-	18.49	0.712	-	0.728
e	-	1.27	-	-	0.050	-
L	7.62	-	9.91	0.300	-	0.390
M	12.50	-	12.09	0.492	-	0.508

XG530

Figure 14: 28-Lead Ceramic Flatpack (Solder Seal) - Package Style F

Function	Pin Number Option D and F	Via	Static 1	Static 2	Dynamic	Radiation
A12	2	R	5V	0V	F14	5V
A7	3	R	5V	0V	F7	5V
A6	4	R	5V	0V	F9	5V
A5	5	R	5V	0V	F8	5V
A4	6	R	5V	0V	F11	5V
A3	7	R	5V	0V	F10	5V
A2	8	R	5V	0V	F5	5V
A1	9	R	5V	0V	F4	5V
A0	10	R	5V	0V	F3	5V
D/Q0	11	R	5V	0V	F1	5V
D/Q1	12	R	5V	0V	F1	5V
D/Q2	13	R	5V	0V	F1	5V
GND(VSS)	14	Direct	0V	0V	0V	0V
D/Q3	15	R	5V	0V	F1	5V
D/Q4	16	R	5V	0V	F1	5V
D/Q5	17	R	5V	0V	F1	5V
D/Q6	18	R	5V	0V	F1	5V
D/Q7	19	R	5V	0V	F1	5V
CSB	20	R	5V	0V	F15	5V
A10	21	R	5V	0V	F2	5V
OEB	22	R	5V	0V	F15	5V
A11	23	R	5V	0V	F6	5V
A9	24	R	5V	0V	F13	5V
A8	25	R	5V	0V	F12	5V
CE	26	R	5V	0V	F15B	5V
WB	27	R	5V	0V	F0	5V
VDD	28	Direct	5V	5V	5V	5V

1. $F_0=150\text{KHz}$, $F_1=F_0/2$, $F_2=F_0/4$, $F_3=F_0/8$ etc.
2. Static 1, Static 2 and Dynamic: $R=4k7$.
3. Radiation: $R=10k$.

Figure 15: Burnin and Radiation Configuration

RADIATION TOLERANCE

Total Dose Radiation Testing

For product procured to guaranteed total dose radiation levels, each wafer lot will be approved when all sample devices from each lot pass the total dose radiation test.

The sample devices will be subjected to the total dose radiation level (Cobalt-60 Source), defined by the ordering code, and must continue to meet the electrical parameters specified in the data sheet. Electrical tests, pre and post irradiation, will be read and recorded.

Dynex Semiconductor can provide radiation testing compliant with MIL-STD-883 test method 1019, Ionizing Radiation (Total Dose).

Total Dose (Function to specification)*	1x10 ⁵ Rad(Si)
Transient Upset (Stored data loss)	5x10 ¹⁰ Rad(Si)/sec
Transient Upset (Survivability)	>1x10 ¹² Rad(Si)/sec
Neutron Hardness (Function to specification)	>1x10 ¹⁵ n/cm ²
Single Event Upset**	4.3x10 ⁻¹¹ Errors/bit day
Latch Up	Not possible

* Other total dose radiation levels available on request

** Worst case galactic cosmic ray upset - interplanetary/high altitude orbit

Figure 16: Radiation Hardness Parameters

SINGLE EVENT UPSET CHARACTERISTICS

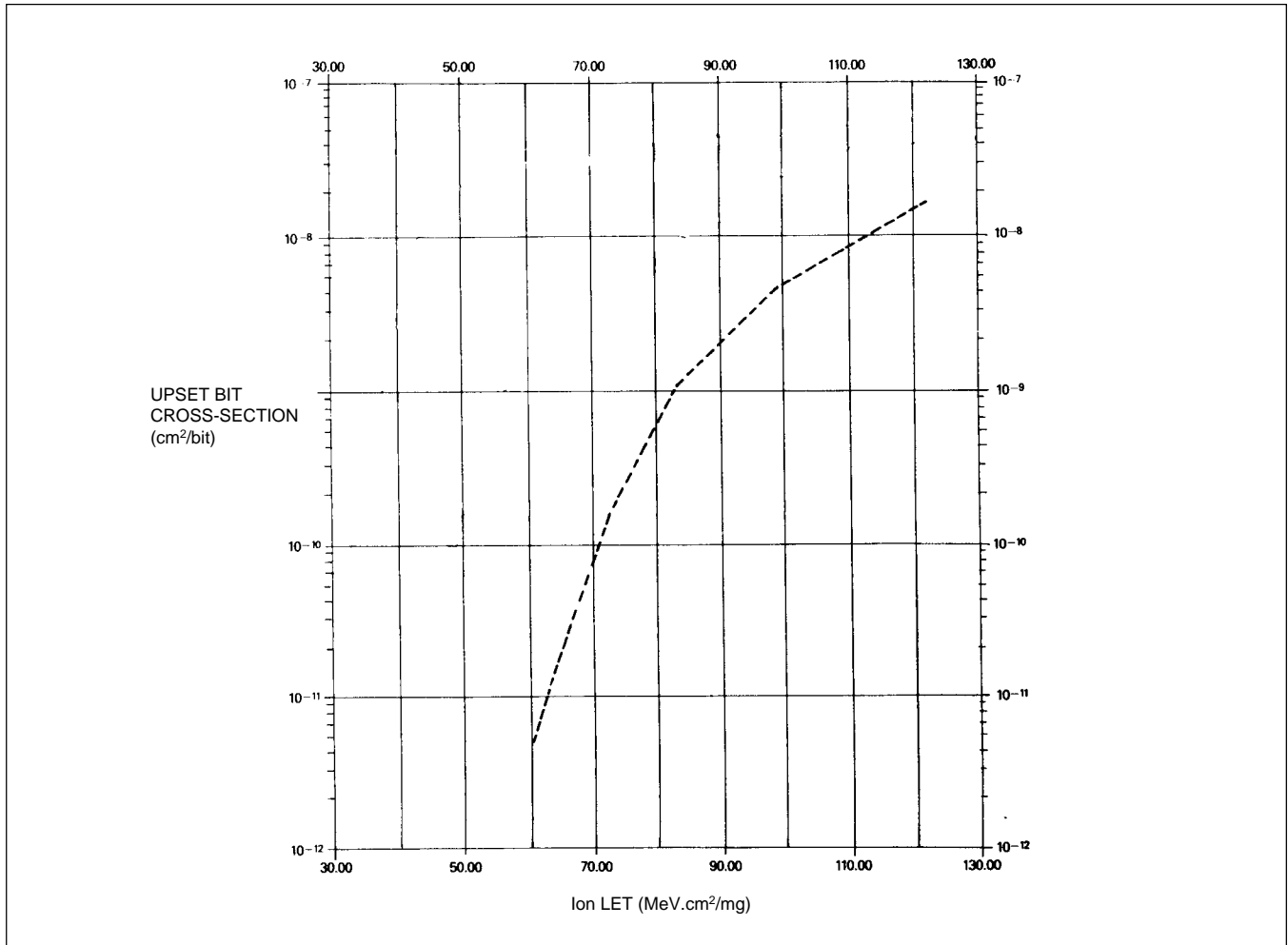
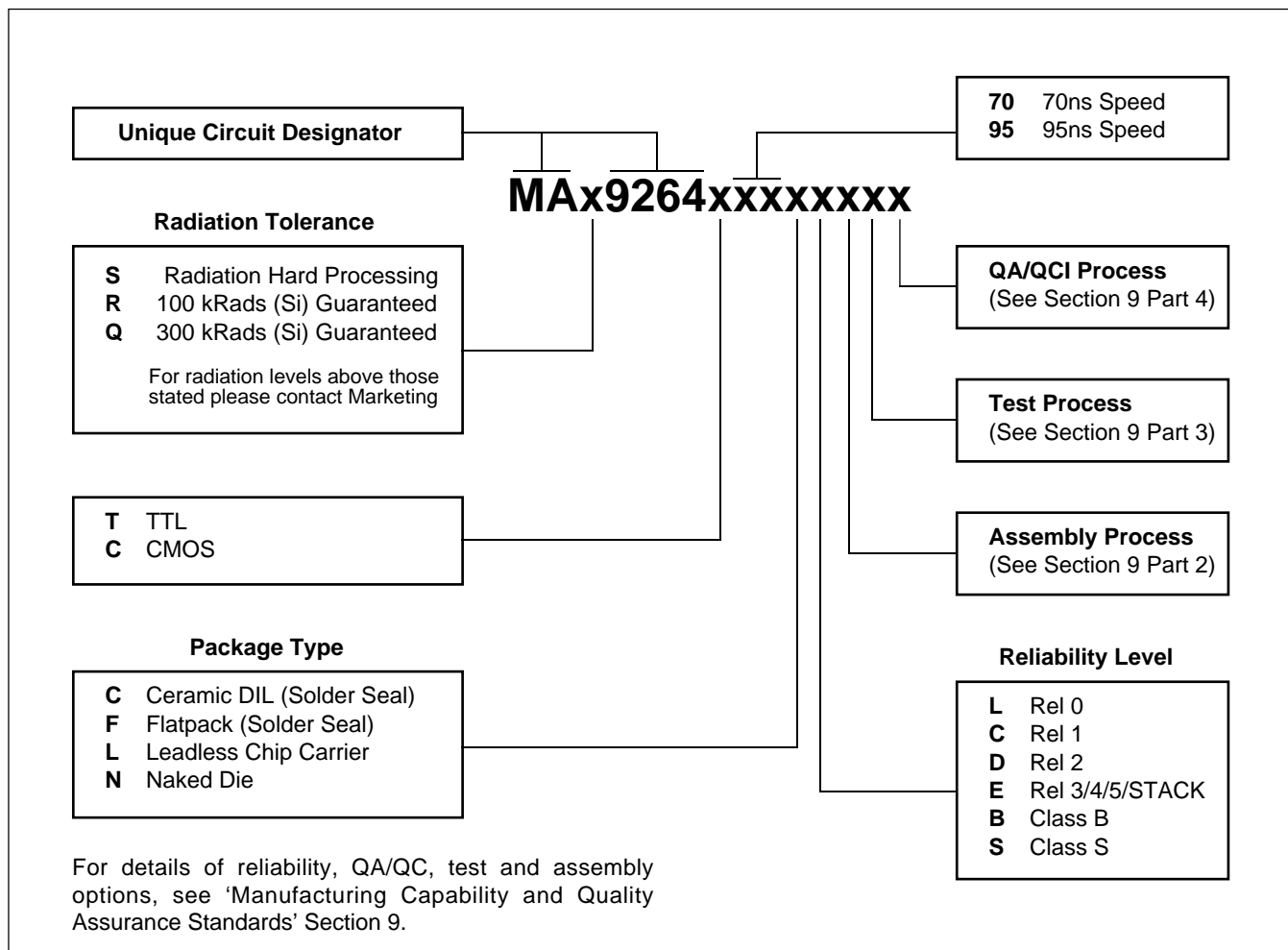

Figure 17: Typical Per-Bit Upset Cross-Section vs Ion LET

ORDERING INFORMATION





<http://www.dynexsemi.com>

e-mail: space_comms@dynexsemi.com

HEADQUARTERS OPERATIONS
DYNEX SEMICONDUCTOR LTD
Doddington Road, Lincoln.
Lincolnshire. LN6 3LF. United Kingdom.
Tel: +44-(0)1522-500500
Fax: +44-(0)1522-500550

CUSTOMER SERVICE
Tel: +44 (0)1522 502753 / 502901. Fax: +44 (0)1522 500020

SALES OFFICE
Tel: +44 (0)1522 502724. Fax: +44 (0)1522 502777

These offices are supported by Representatives and Distributors in many countries world-wide.
© Dynex Semiconductor 2002 TECHNICAL DOCUMENTATION – NOT FOR RESALE. PRODUCED IN
UNITED KINGDOM

Datasheet Annotations:

Dynex Semiconductor annotate datasheets in the top right hand corner of the front page, to indicate product status. The annotations are as follows:-

Target Information: This is the most tentative form of information and represents a very preliminary specification. No actual design work on the product has been started.

Preliminary Information: The product is in design and development. The datasheet represents the product as it is understood but details may change.

Advance Information: The product design is complete and final characterisation for volume production is well in hand.

No Annotation: The product parameters are fixed and the product is available to datasheet specification.

This publication is issued to provide information only which (unless agreed by the Company in writing) may not be used, applied or reproduced for any purpose nor form part of any order or contract nor to be regarded as a representation relating to the products or services concerned. No warranty or guarantee express or implied is made regarding the capability, performance or suitability of any product or service. The Company reserves the right to alter without prior notice the specification, design or price of any product or service. Information concerning possible methods of use is provided as a guide only and does not constitute any guarantee that such methods of use will be satisfactory in a specific piece of equipment. It is the user's responsibility to fully determine the performance and suitability of any equipment using such information and to ensure that any publication or data used is up to date and has not been superseded. These products are not suitable for use in any medical products whose failure to perform may result in significant injury or death to the user. All products and materials are sold and services provided subject to the Company's conditions of sale, which are available on request.

All brand names and product names used in this publication are trademarks, registered trademarks or trade names of their respective owners.
